



***Operating  
instructions  
ENESKAmicro 600  
ENESKAmicro 450  
ENESKAmicro 600 PLC***



## Table of contents

<b>1</b>	<b>Notes on this manual</b>	<b>4</b>
<b>2</b>	<b>Product overview</b>	<b>4</b>
<b>3</b>	<b>Technical data</b>	<b>5</b>
3.1	Nameplate	8
<b>4</b>	<b>Safety</b>	<b>9</b>
4.1	Intended use	9
4.2	General safety instructions	9
4.3	Safety markings on the unit	9
<b>5</b>	<b>Controls and indicators</b>	<b>10</b>
<b>6</b>	<b>Commissioning of the controller</b>	<b>11</b>
6.1	Replacing the fuse (if necessary)	11
6.2	Setting up the control unit	12
6.3	Connecting the mains cable and switching on the unit	13
6.4	Connecting the motor cable to the unit	14
6.5	Connecting a handpiece	15
6.6	Setting the language (if necessary)	16
<b>7</b>	<b>Commissioning of the motor on the controller</b>	<b>17</b>
7.1	Switching the unit on and off	17
7.2	Selecting a motor	17
7.3	Selecting the direction of rotation	18
7.4	Setting the speed	19
7.5	Starting the motor	20
7.6	Stopping the motor	20
7.7	Using the memory function (MEM)	21
<b>8</b>	<b>Main menu overview</b>	<b>22</b>
<b>9</b>	<b>Opening the main menu and navigating within menus</b>	<b>23</b>
<b>10</b>	<b>Displaying information about the unit</b>	<b>24</b>
<b>11</b>	<b>Unit functions in the "Options" menu</b>	<b>25</b>
11.1	Setting the "Timer" option	25
11.2	Switching the direction of rotation on and off via the handpiece	25
11.3	Adjusting the speed limiter in anti-clockwise rotation	26
11.4	Activating the "Foot pedal memory" (MEM foot pedal) option	26
11.5	Activating the "Diagnostics screen" option	27
11.5.1	Overview of "Diagnostics Screen"	28
11.6	"External control input" option (ext. input) assign	29
<b>12</b>	<b>Using the foot pedal on the external input</b>	<b>30</b>
12.1	Fixing the speed of the foot pedal (FIX-it)	31
<b>13</b>	<b>PLC operating mode for external motor control (ENESKAmicro 600 PLC only)</b>	<b>33</b>
13.1	Keys in PLC mode	33
13.2	Main display in PLC mode	34
13.3	Activating PLC operating mode	34

13.4	<b>Parametrising the PLC</b> .....	<b>35</b>
13.4.1	Activate “Run/stop” mode and specify the set speeds .....	35
13.4.2	Activating analogue control.....	35
13.5	<b>Connecting the PLC</b> .....	<b>36</b>
<b>14</b>	<b>“Interface” menu access options</b> .....	<b>38</b>
14.1	<b>Firmware update</b> .....	<b>38</b>
14.2	<b>PLC control</b> .....	<b>38</b>
14.3	<b>Bearing RunIn</b> .....	<b>38</b>
14.4	<b>Reset</b> .....	<b>38</b>
<b>15</b>	<b>Fitting the tool and collet</b> .....	<b>39</b>
15.1	<b>Changing the tool</b> .....	<b>39</b>
15.1.1	Compact SE, HT60, HT60 SMALL, HT60-XL .....	39
15.1.2	HT60-D6 (CNC) .....	40
15.1.3	JEHG 400, JHG 210.....	40
15.1.4	JEHR 500, JIR 310, JEM 50C (CNC), JIR 40R,.....	41
15.1.5	JERA 270 .....	41
15.1.6	JBMLH 40R, JBMH 300 N, JBMLH 40R, JEHG 20R .....	42
15.1.7	JERA 270 S .....	42
15.1.8	JIH 300, JIH 40R .....	43
15.1.9	JKC 345, JIC 390, JEKC 300, WE4-45, WE4-90, JERA 90 20R, JEAH 60 20R .....	43
15.1.10	JMFC 300 S, JMFC 300 M .....	44
15.2	<b>Changing the collet</b> .....	<b>45</b>
15.2.1	COMPACT SE .....	45
15.2.2	HT60, HT60-XL .....	46
15.2.3	HT60-D6 (CNC) .....	46
15.2.4	HT60 SMALL .....	47
15.2.5	JEHG 400, JHG 210.....	48
15.2.6	JEHR 500, JIR 310.....	48
15.2.7	JBMLH 40R, JEM 50C (CNC), JIR 40R, JBMH 300 N, JBMLH 40R, JEHG 20R ..	49
15.2.8	JERA 270 .....	49
15.2.9	JERA 270 S .....	50
15.2.10	JIH 300, JIH 40R .....	50
15.2.11	JKC 345, JIC 390, JEKC 300, WE4-45, WE4-90, JERA 90 20R, JEAH 60 20R .....	51
15.2.12	JMFC 300 S, JMFC 300 M .....	51
<b>16</b>	<b>Maintenance, care and disposal</b> .....	<b>52</b>
16.1	<b>Servicing and maintenance instructions</b> .....	<b>52</b>
<b>17</b>	<b>Troubleshooting</b> .....	<b>53</b>
	<b>Declaration of Conformity</b> .....	<b>56</b>
	<b>Declaration of Conformity</b> .....	<b>57</b>

## 1 Notes on this manual

These operating instructions enable the operator to operate, service and maintain the ENESKA-micro System 450, 600 or 600 PLC. These operating instructions are part of the system and must always be kept at hand at the place of use.

- ▶ If you pass on the ENESKA-micro system to third parties, please include these operating instructions.

Instructions which must be strictly observed to prevent hazards or damage are marked as follows:



### Warning!

Warns of hazards that could result in serious injury or death.



### Attention!

Warns of hazards that can lead to damage to objects.

- ▶ For technical problems or other questions please contact our service department.

## 2 Product overview

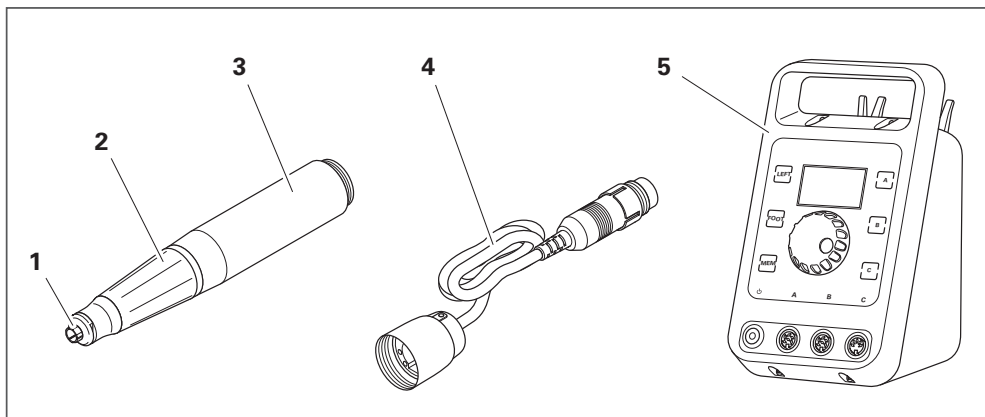

Fig. 1

1	Collet	4	Motor cable
2	Handpiece	5	ENESKA-micro control unit
3	Motor		

You will find a comprehensive system overview in the joke surface treatment catalogue, in the “Drive systems and handpieces” section.

### 3 Technical data

<b>ENESKAmicro 450 control unit</b>	
Motor connections	<b>2 connections for brushless DC motors</b>
Supply voltage	115/230 V, 50/60 Hz
Unit micro-fuse	T4A/T2A (250 V~)
Transformer capacity	175 VA (for BV1591 2 x 20 V + 8 V)
Switch-on time	ED70
With temperature fuse	110 °C
Unit protection against overload	Unit switches off in event of: <ul style="list-style-type: none"> <li>• Overtemperature of the controller</li> <li>• Motor overcurrent</li> </ul>
Max. speed	45 000 rpm
Fuse rating of power supply	16 A
Dimensions (W x H x D)	135 x 235 x 200 mm
Weight	3.6 kg
Ambient conditions	0 °C to +40 °C 10 % to 85 % humidity
USB charging port	USB Type-A, 5 V to 1.8 A

<b>ENESKAmicro 600 and 600 PLC control unit</b>	
Motor connections	<b>Connections A and B for brushless DC motors Connection C for carbon brush motors</b>
Supply voltage	115/230 V, 50/60 Hz
Unit micro-fuse	T4A/T2A (250 V~)
Transformer capacity	175 VA (for BV1591 2 x 20 V + 8 V)
Switch-on time	ED70
With temperature fuse	Fuse: 110 °C
Unit protection against overload	Unit switches off in event of: <ul style="list-style-type: none"> <li>• Overtemperature of the controller</li> <li>• Motor overcurrent</li> </ul>
Max. speed	<b>60 000 rpm</b>
Fuse rating of power supply	16 A
Dimensions (W x H x D)	135 x 235 x 200 mm
Weight	3.6 kg
Ambient conditions	0 °C to +40 °C 10 % to 85 % humidity
USB charging port	USB Type-A, 5 V to 1.8 A

Approved motors	Max. speed (rpm)	Handpiece – motor connection	Motor cable
ENESKAmicro motor SE3	50 000	(-)	ENESKAmicro S
ENESKAmicro motor SE4	50 000	(+)	ENESKAmicro S
ENESKAmicro COMPACT SE	50 000	COMPACT	ENESKAmicro HT
ENESKAmicro COMPACT HT60	60 000	COMPACT	ENESKAmicro HT
ENESKAmicro COMPACT HT60 SMALL	60 000	COMPACT	ENESKAmicro HT
ENESKAmicro COMPACT HT60-XL	50 000	COMPACT	ENESKAmicro HT
ENESKAmicro COMPACT HT60-D6	50 000	COMPACT	ENESKAmicro HT
ENESKAmicro COMPACT HT60-D6 CNC	50 000	COMPACT	ENESKAmicro HT
ENESKAmicro COMPACT JEM 50C	50 000	COMPACT	JEM 50C
ENESKAmicro COMPACT JEM 50C CNC	50 000	COMPACT	JEM 50C
Micromotor JBM 50 HT	50 000	(+)	JBM 50 S/EM
Micromotor JBM 50 S	50 000	(+)	JBM 50 HT/EM
Micromotor JENK-250T	25 000	(-)	JENK-250T/EM
Micromotor JENK-410S	40 000	(-)	JENK-410S/EM
Micromotor JNK-261		(-)	NCL-261
Micromotor JNK-351		(-)	NCL-631
Micromotor JEM 40R	40 000	Rapid change	JEM 40R
Micromotor JEM 20R	25 000	Rapid change	JEM 20R
Micromotor JEM 50R	50 000	Rapid change	JEM 50C/50R
Marathon 3rd party motor	60 000	(+)/(-)	SDE-BH60/EM

Approved reduction gearbox	Max. speed (rpm)	Speed reduction	Connection
JRG 01	30 000	4 : 1	(-)
JERG 01 B	30 000	4 : 1	(+)
JERG 2	30 000	4 : 1	Rapid change

Approved adapters	Max. speed (rpm)	Function
JECN 01 T	35 000	Handpieces with a (-) connection can be connected to motors with a (+) connection
JECR 01	40 000	Handpiece adapter for ENESKA 4 handpieces with ENESKA JEM "R" series
JECR 02	40 000	Handpiece adapter for ENESKA 3 handpieces with ENESKA JEM "R" series
JECR 03	40 000	Handpiece adapter for ENESKA JEM "R" handpieces on ENESKA 4 motor series
JECR 04	40 000	Handpiece adapter for ENESKA JEM "R" handpieces on ENESKA 3 motor series

Approved extenders	Max. speed (rpm)	Connection
JCN 01	35 000	(-)
JEEA	40 000	Rapid change

Approved handpieces with a (+) connection	Max. speed (rpm)
JBS 400 belt grinder	15 000
DIPROFIL Di-Pro FXM-N, Mark II hand-held filing machine	7 000 (strokes)
DIPROFIL FPM/ERJ, Mark II hand-held filing machine	7 000 (strokes)
DIPROFIL FPT/ER, Mark II hand-held filing machine	8 000 (strokes)
FMD/3-2/EM hand-held filing machine	7 800 (strokes)
JFMM 4 hand-held filing machine	7 800 (strokes)
JEHG 400 handpiece	30 000
DIPROFIL FMR/E mini hand-held filing machine	8 000 (strokes)
JN 48 mini hand-held filing machine	12 500 (strokes)
FMV/E cross-stroke handpiece	8 000 (strokes)
JEHR 500 quick-release handpiece	50 000 (continuous operation: 40 000)
JEKC 300 angled handpiece	20 000
JERA 270 angled handpiece	20 000
JERA 270 S angled handpiece	18 000
WE4-45 angled handpiece	30 000
WE4-90 angled handpiece	30 000

Approved handpieces with a (-) connection	Max. speed (rpm)
JBS 100 belt grinder	13 000
DIPROFIL Di-Pro FXM-N, Mark II hand-held filing machine	7 000 (strokes)
DIPROFIL FPM/ERJ, Mark II hand-held filing machine	7 000 (strokes)
DIPROFIL FPT/NR, Mark II hand-held filing machine	8 000 (strokes)
FMD/3-2 hand-held filing machine	7 800 (strokes)
JFMM 3 hand-held filing machine	7 800 (strokes)
JBMH 300 N handpiece	35 000
JHG 210 handpiece	27 000
JMFC 300 M miniature angled handpiece	15 000
JMFC 300 S miniature angled handpiece	15 000
DIPROFIL FMR/N mini hand-held filing machine	8 000 (strokes)
JN 38 mini hand-held filing machine	10 000 (strokes)
DIPROFIL FMV/N cross-stroke handpiece	8 000 (strokes)
JIH 300 quick-release handpiece	40 000
JIR 310 quick-release handpiece	40 000
JIC 390 angled handpiece	20 000
JKC 345 angled handpiece	20 000

Approved handpieces with rapid change connection	Max. speed (rpm)
JIR 40R quick-release handpiece	50 000 (continuous operation: 40 000)
JIH 40R one-handed handpiece	50 000 (continuous operation: 40 000)
JBMLH 40R handpiece	40 000
JBMLH 40R handpiece	40 000
JEHG 20R handpiece	20 000
JERA 90 20R angled handpiece	20 000
JEAH 60 20R angled handpiece	20 000
JBS 20R belt grinder	20 000
JMH 20R mini hand-held filing machine	20 000
FMD/R	20 000

### 3.1 Nameplate

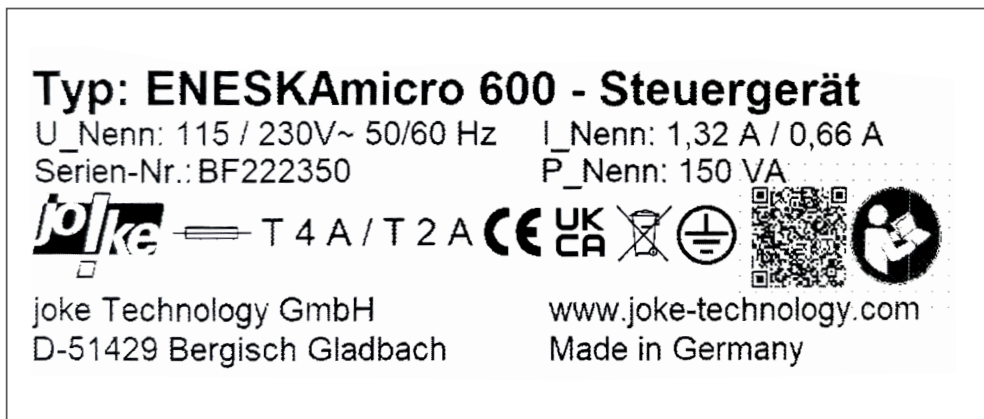

Fig. 2

On the control unit nameplate, you will find:

- Manufacturer's mark and address,
- Type designation: ENESKAmicro XXX - control unit
- CE marking and other marks
- Serial number
- Technical data:
  - Rated voltage
  - Rated current
  - Nominal and power rating

The control unit nameplate is located on the rear of the unit.



## 4 Safety

### 4.1 Intended use

ENESKAmicro systems are designed exclusively for grinding, milling, deburring and polishing with the tools listed and approved in the joke catalogue.

ENESKAmicro systems may only be used with approved components and accessories (see chapter 3 "Technical data" on page 5).

The ENESKAmicro PLC control units are controlled by a customer's external controller. The external control must not exceed the technical limits of the unit, in particular the power transmission, as well as the normal operating times in manual mode. The electrical connections require specialist knowledge in electrical engineering and automation. PLC connection and unit operation are the responsibility of the user.

ENESKAmicro control units may only be used as described in these operating instructions. Any different or additional use is considered improper use. The manufacturer will not be liable for damage resulting from improper use.

### 4.2 General safety instructions

To avoid danger to persons and material damage, you must ALWAYS observe the following safety instructions:

- ▶ Read the operating instructions before working with the unit.
- ▶ Make sure that these operating instructions are accessible to all persons working with the unit.
- ▶ Use ENESKAmicro systems only in technically sound condition and only with undamaged cables.
- ▶ Please note that the values specified in the technical specifications of the individual components must not be exceeded when working with the ENESKAmicro system.
- ▶ Always place the ENESKAmicro system control unit on a safe, non-slip surface.
- ▶ Always route all cables so that they cannot, for example, be damaged by pulling and in such a way that no one can stumble over them.
- ▶ When working with the ENESKAmicro system, always wear safety glasses, safety gloves and hearing protection.
- ▶ Ensure sufficient extraction of any dust particles that may arise.
- ▶ Eliminate faults immediately according to these instructions or have them eliminated by joke Service.
- ▶ Use only original parts from the joke.
- ▶ Only use the carrying handle on the control unit to manually lift and transport the unit.
- ▶ Switch off the control unit before each transport.
- ▶ Remove the mains cable and all other connecting cables before each transport.

#### Personnel qualifications

The use of the product requires special instruction and concentration during use. It is the responsibility of the employer/operator to select suitable personnel to use this product.

### 4.3 Safety markings on the unit

The following safety markings on the unit must be legible and undamaged at all times.



Observe the instructions

## 5 Controls and indicators

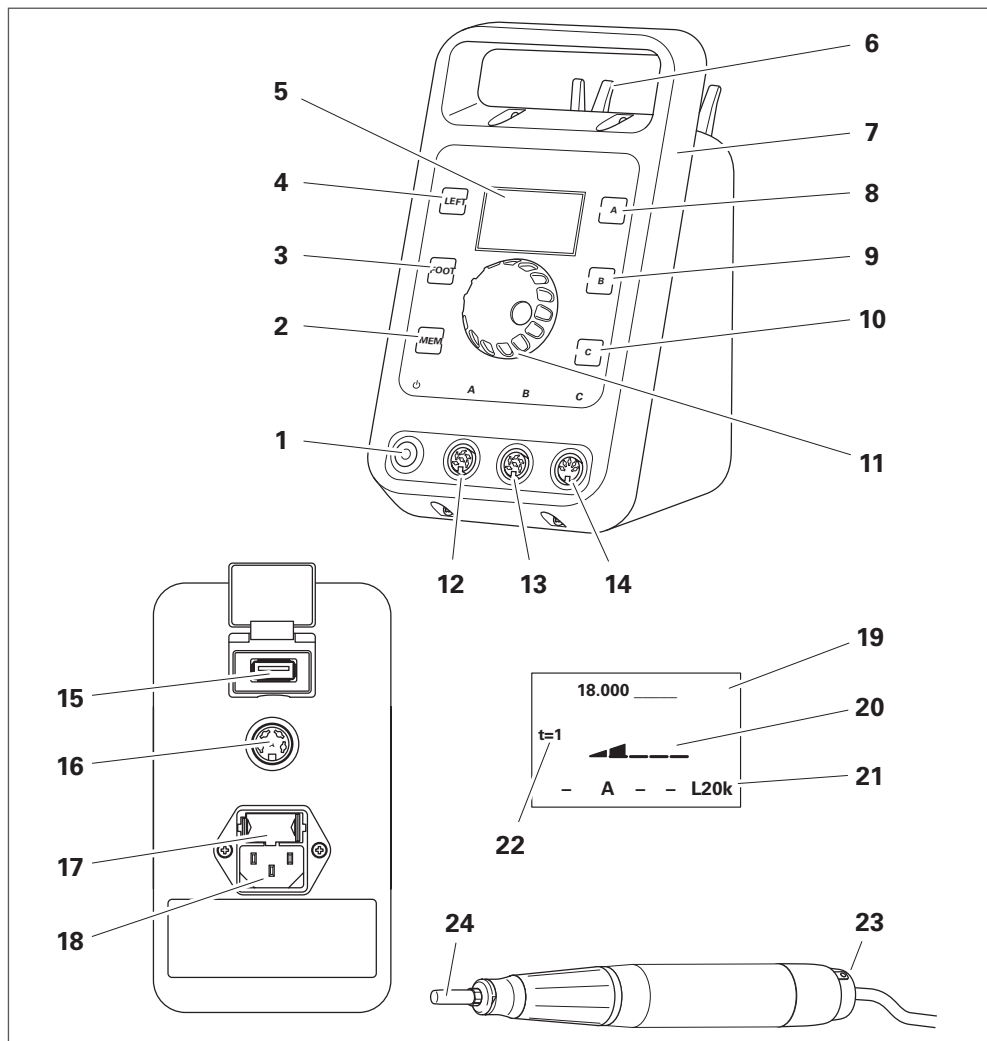

Fig. 3

1	Power switch	13	Connection B (BLDC - brushless DC motor)
2	[MEM] button	14	Connection C (DC carbon brush motor; if available)
3	[FOOT] button	15	USB charging socket (type A)
4	[LEFT] button	16	Foot pedal or PLC connection (PLC depending on version)
5	Display	17	Fuse
6	Handpiece rest (if available)	18	Mains plug connection
7	Carrying handle	19	Speed display as actual value or %
8	Motor button [A]	20	Speed display as a bar when active
9	Motor button [B]	21	Information area: Plugged-in motors and foot pedal or speed limitation anti-clockwise rotation
10	Motor button [C] (function depends on version)	22	Display of timer function
11	Rotary controller/rotary encoder	23	On/off switch on motor (or handpiece)
12	Connection A (BLDC - brushless DC motor)	24	Tool

## 6 Commissioning of the controller



### Note

The operation described in the following chapters is based on software versions V.04x and V.05x. For units with older versions, the information is not valid.

### 6.1 Replacing the fuse (if necessary)

The control unit is factory set to 230 V and equipped with two 2 A micro-fuses. One of these two is intended to be a spare. Two 4 A micro-fuses are also included.



### Attention!

- ▶ Before connecting the unit to the power supply, check the setting of the power supply unit.
- ▶ If necessary, adjust the setting of the mains connection unit to the country-specific mains voltage. To do this, you can switch the mains voltage to 115 V or 230 V via the fuse link.
- ▶ If you change the mains voltage, you must use the appropriate micro-fuse.
- ▶ Use only micro-fuses with breaking capacity L:
  - Micro-fuse 5 x 20 mm, T2A/250 V for 230 V connections
  - Micro-fuse 5 x 20 mm, T4A/250 V for 115 V connections

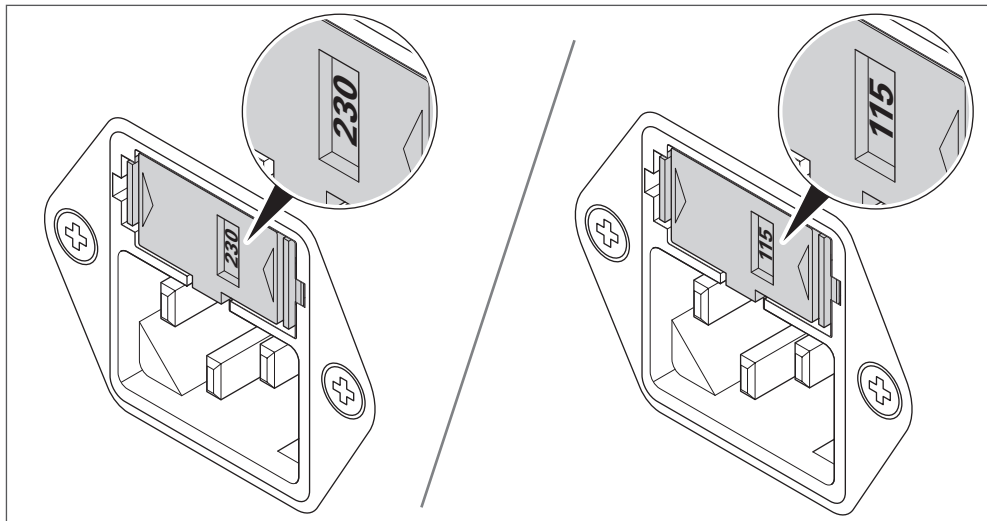

Fig. 4

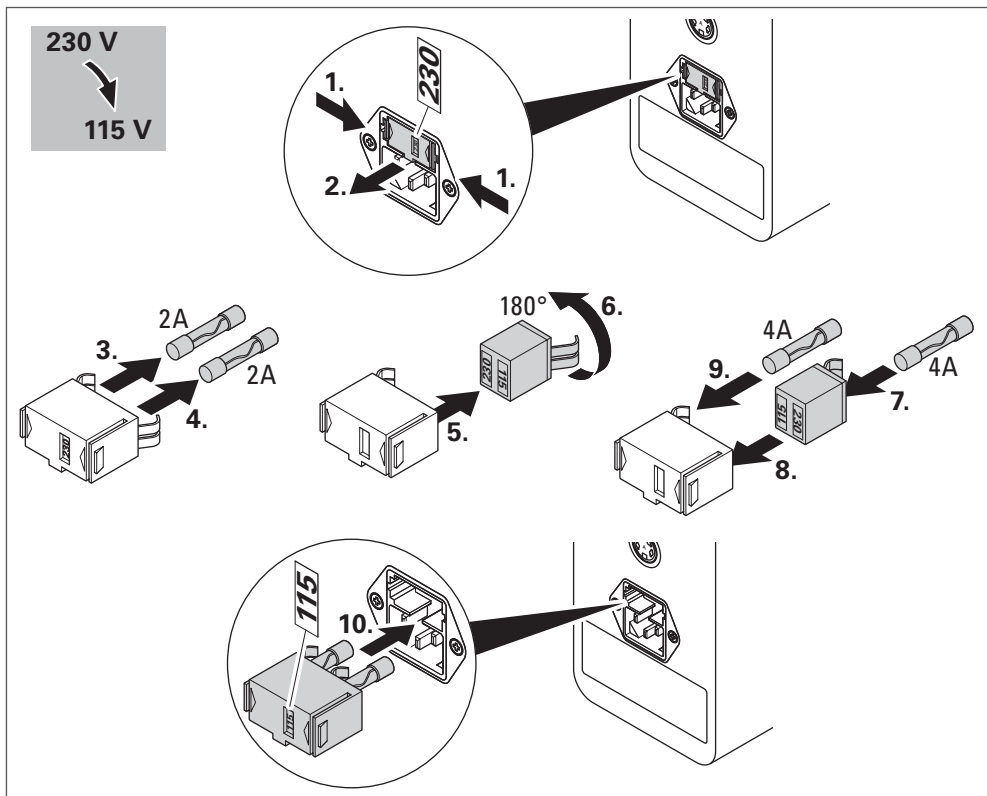

Fig. 5

## 6.2 Setting up the control unit



### Attention!

Humidity entering the unit or its accessories may cause a short circuit.

- ▶ Do not use the unit or its accessories in conditions that may cause condensation to occur in or on product parts, such as when the product has been moved from a cold to a warm environment.
- ▶ If necessary, let the product acclimatise for a few hours at the installation site.
- ▶ Make sure that the control unit location is dry and meets the ambient conditions requirements (for environmental conditions requirements see chapter 3 "Technical data" on page 5).

### 6.3 Connecting the mains cable and switching on the unit

- ▶ Route the mains cable of the control unit so that it is easily accessible and that you can easily disconnect the unit from the power supply.
- ▶ Use only the original mains cable or approved equivalent power cord.

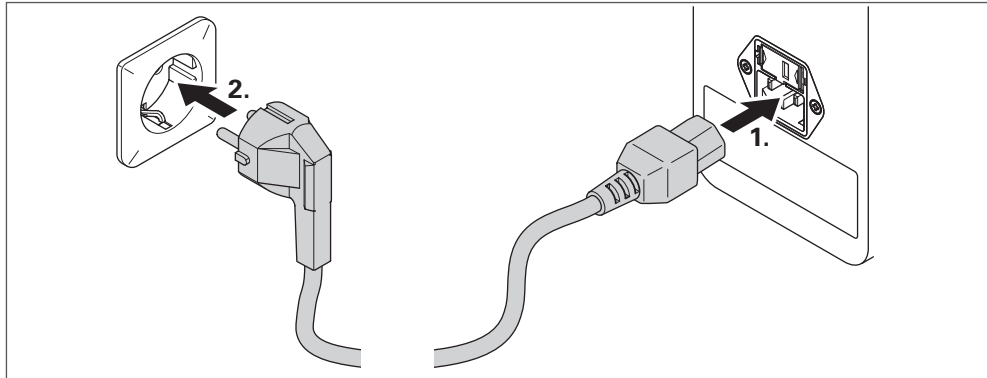

Fig. 6

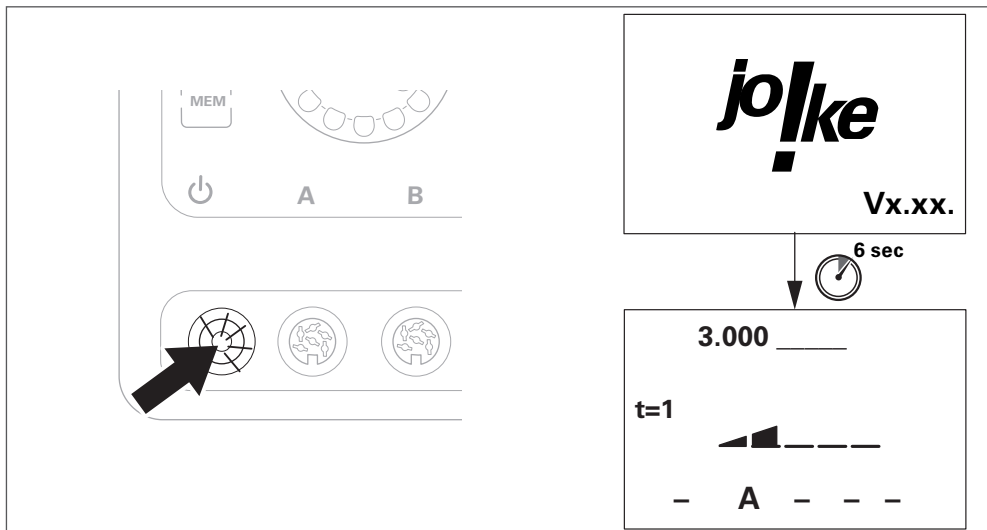

Fig. 7

Immediately after switching on, the unit displays the joke logo and firmware version.

## 6.4

### Connecting the motor cable to the unit



#### Attention!

► Always insert the cable carefully into the socket on the control unit and make sure that the contacts and threads are not damaged.

- Connection A: Brushless DC motor
- Connection B: Brushless DC motor
- Connection C: Carbon brush DC motor

The connected motor channel is indicated as active by the associated motor button flashing ([A], [B] or [C]).

► If you connect a third-party motor to connector C, press the motor button [C] to start motor detection.

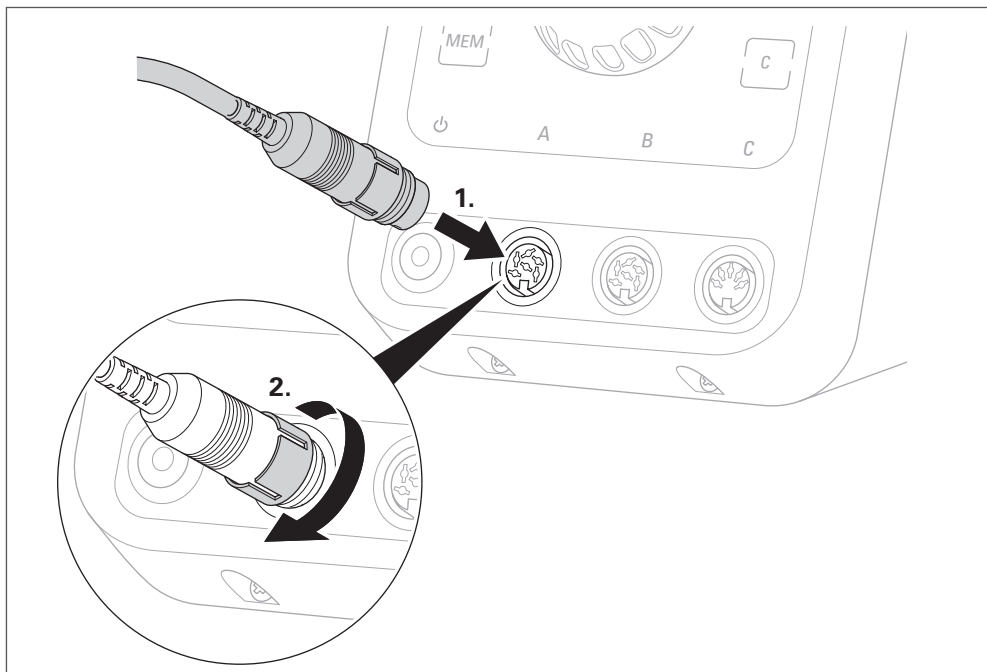

Fig. 8



#### Attention!

► Always connect motor and cable carefully and make sure that the contacts and threads are not damaged.

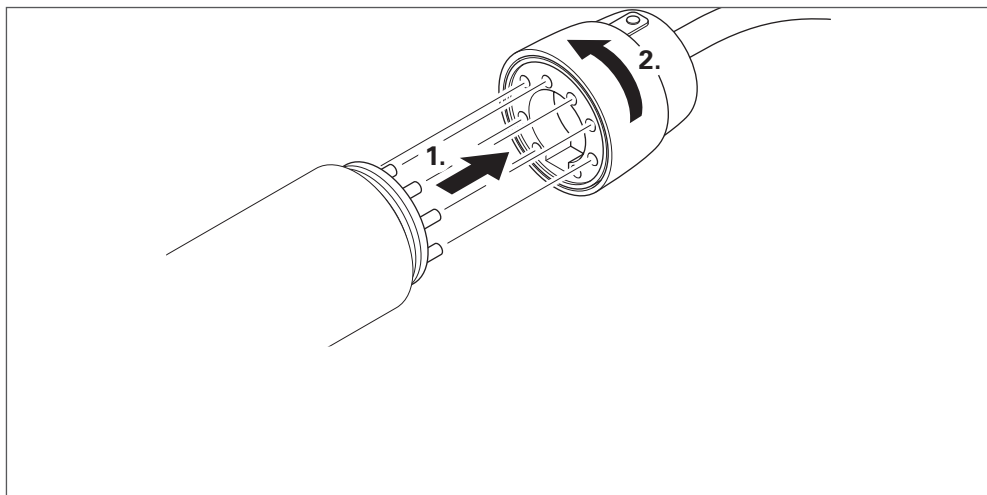

Fig. 9

## 6.5

### Connecting a handpiece



#### Attention!

- ▶ Carefully push the motor and the handpiece together and make sure that the contacts, the motor shaft, the handpiece coupling and the threads are not damaged.
- ▶ Use only the supplied tool.

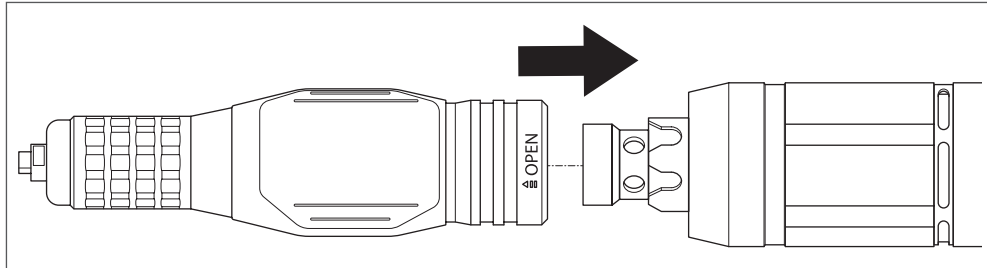

Fig. 10 Connect the motor and handpiece (example illustration)

- ▶ If there is resistance before the thread is completely screwed in, or if the connection is not plugged in properly, first turn the collet of the handpiece manually until the coupling engages.

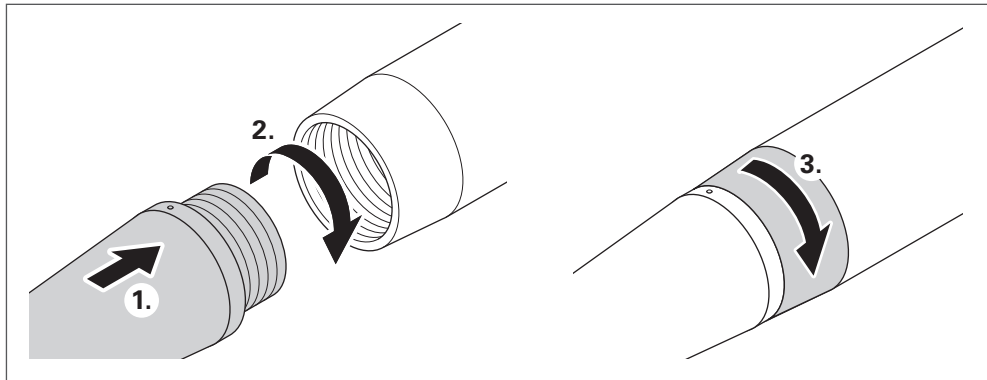
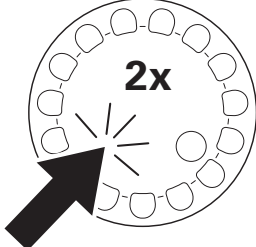
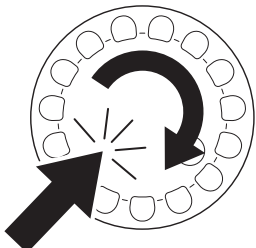
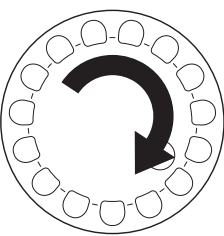
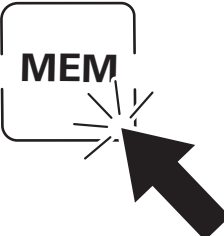
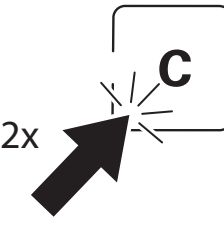

Fig. 11 Inserting and rotating (example illustration)

## 6.6 Setting the language (if necessary)

Action	Display
 <p>Open main menu</p>	<pre> = ESC = Main menu = ----- - Language - Unit info  - Options - Interfaces           </pre>
 <p>Select "Sprache/Language" menu</p>	<pre> = ESC = Main menu = ----- - Language - Unit info  - Options - Interfaces           </pre>
 <p>Select language</p>	<pre> = ESC = _____ = ----- &gt; Deutsch   English   <b>Francais</b> -----   Cestina [MEM]=Save          [C]=ESC           </pre> <p>(example)</p>
 <p>Save language</p>	<pre> = ESC = _____ = -----   Deutsch   English   &gt; <b>Francais</b> -----   Cestina                                      [C]=ESC           </pre> <p>(example)</p>
 <p>Back to start page</p>	<pre> 18.000 _____ t=1   ▲   - A - - - -           </pre>



## 7 Commissioning of the motor on the controller

### 7.1 Switching the unit on and off

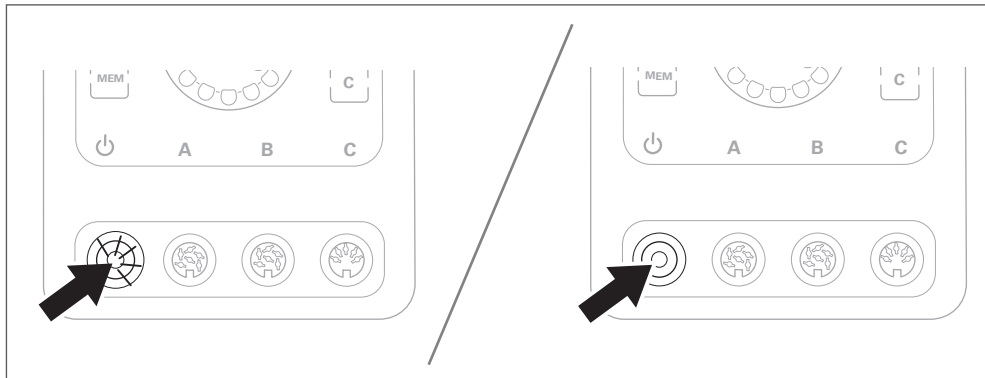

Fig. 12

### 7.2 Selecting a motor

Several motors can be connected to the control unit at the same time, but only one motor can be used at a time.

The motor that was last connected to, or used with, the control unit is automatically selected. The motor button [A], [B] or [C] belonging to this motor will flash.

- ▶ If necessary, press the [A], [B] or [C] motor button once, or alternatively press the ON/OFF button on the motor once to select another motor.

### 7.3 Selecting the direction of rotation

Anti-clockwise rotation can only be selected if the handpiece is approved for two directions of rotation.

#### Option A:

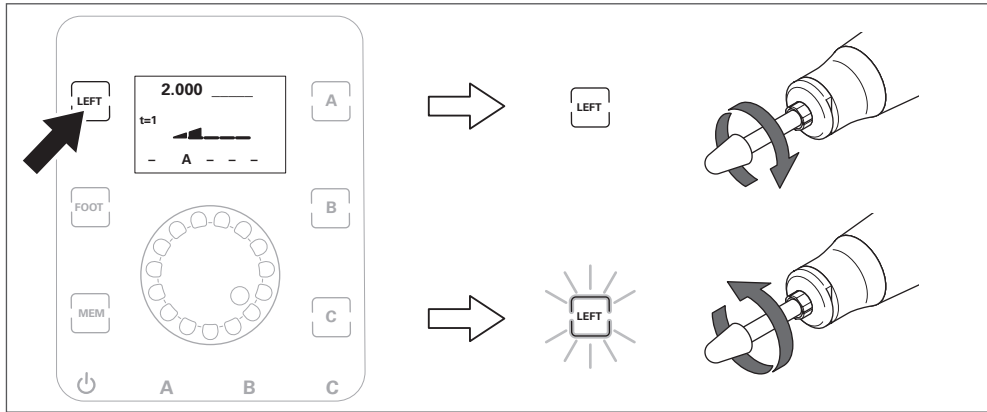

Fig. 13

#### Option B (only if this function has been enabled via the control unit see chapter 11.2 on page 25):

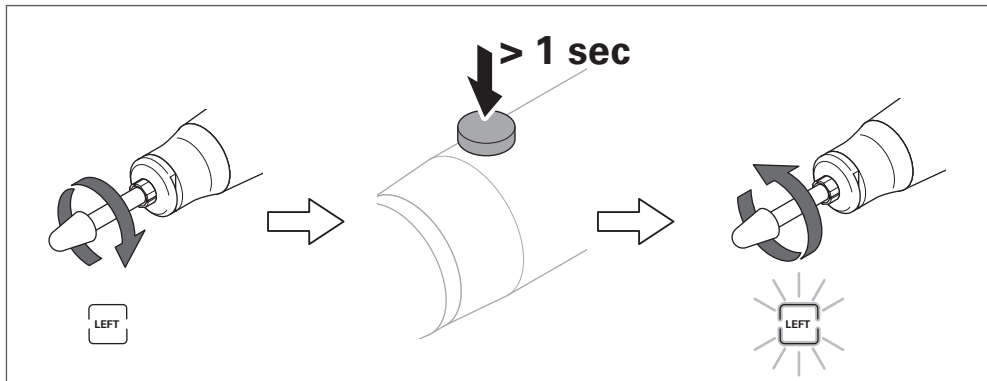

Fig. 14

## 7.4 Setting the speed



### Warning!

- ▶ To prevent injury and damage to components caused by high speeds: Never exceed the maximum permitted speed of the connected components and accessories.



### Attention!

- ▶ To avoid damage to the handpiece: Reduce the speed if the tool protrusion is more than 13 mm.

Tool protrusion	Speed
13 mm to 20 mm	50 % of the approved speed
21 mm to 25 mm	30 % of the approved speed
26 mm to 50 mm	10 % of the approved speed

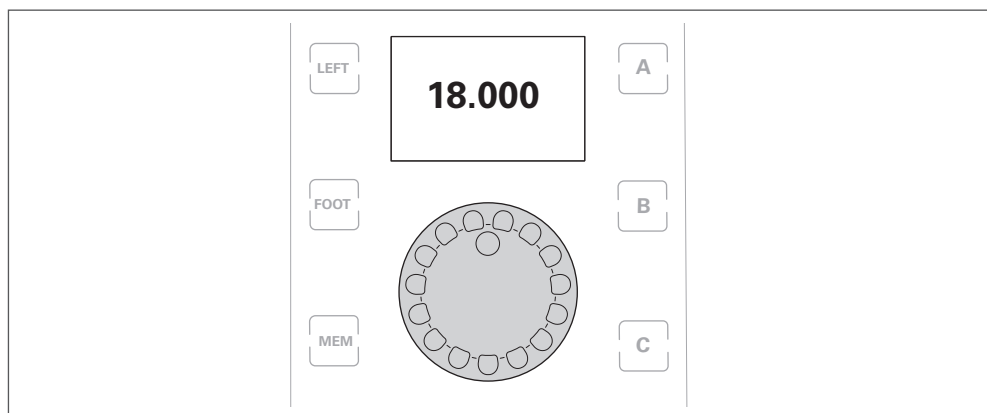

Fig. 15

- ▶ To set the speed limitation in anti-clockwise rotation: see chapter 11.3 on page 26.

### Set speeds between 50,000 and 60,000 1 rpm

ENESKAmicro 600 control units with COMPACT HT60 and HT60 small motors:

The speed setting is initially limited to a maximum of 50,000 rpm. As soon as the display of the speed in large digits is automatically hidden after the setting the speed, you can increase the speed further up to a maximum of 60,000 rpm.

### 7.5 Starting the motor

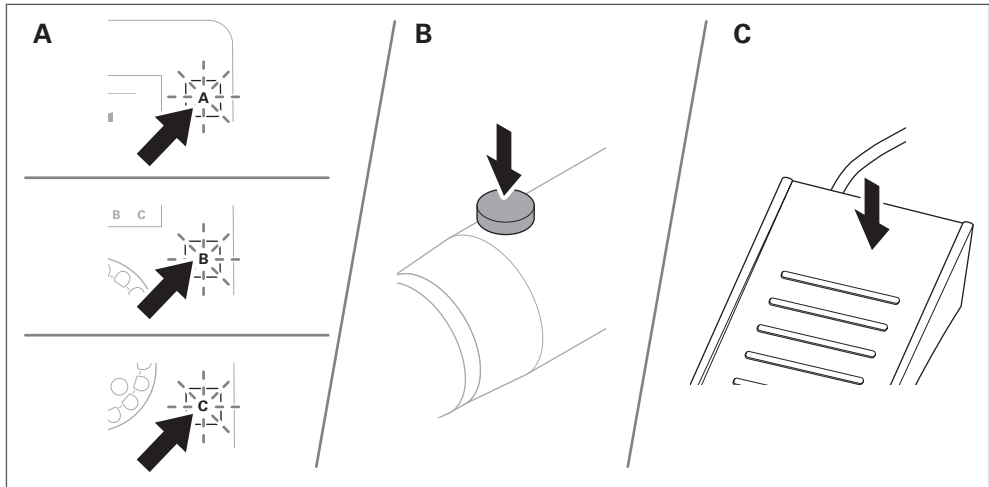

Fig. 16

### 7.6 Stopping the motor

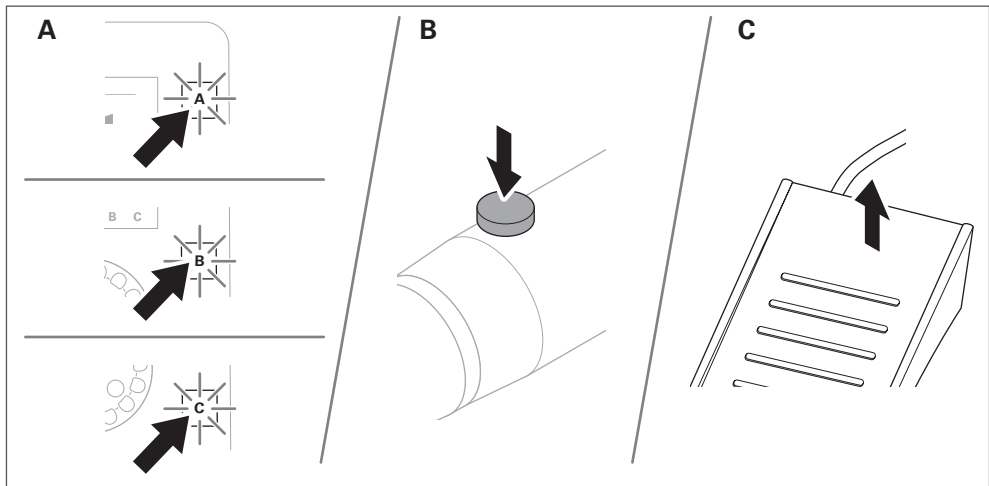

Fig. 17

## 7.7 Using the memory function (MEM)

The memory function makes it possible to store one speed, one direction of rotation (anti-clockwise or clockwise) and the activated foot operation for each of the three connections (A, B or C) so that the settings are retained even if the control unit is switched off and then on again. If the memory function is activated (MEM button illuminated), the settings on the control unit cannot be changed. Before saving, foot operation must be activated separately (in order to activate the switch state of the [FOOT] button for each channel individually, see chapter 11.4 on page 26).

### Saving the settings with the [MEM] button

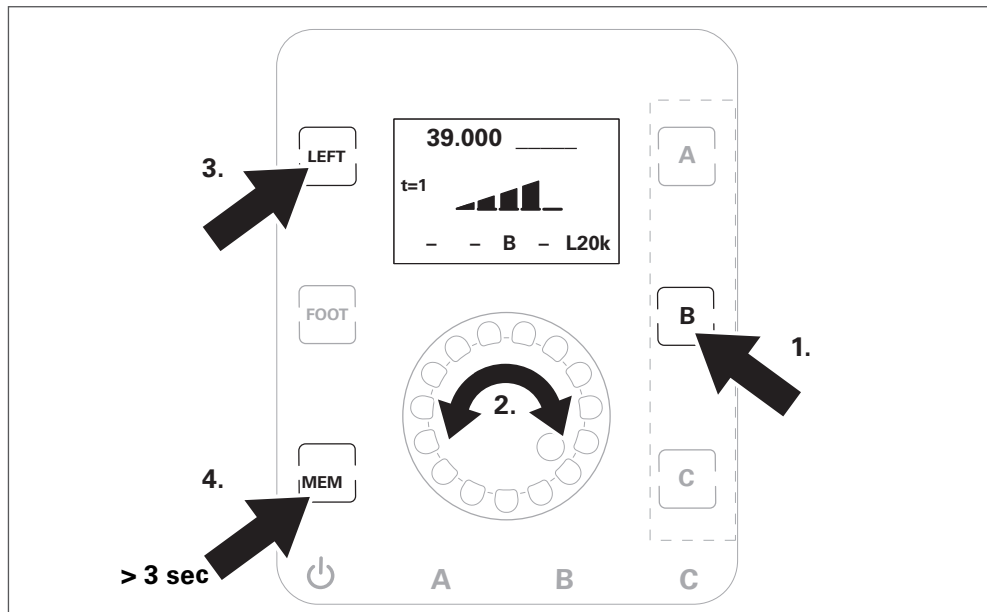

Fig. 18

### Activate/deactivate saved settings with the [MEM] button

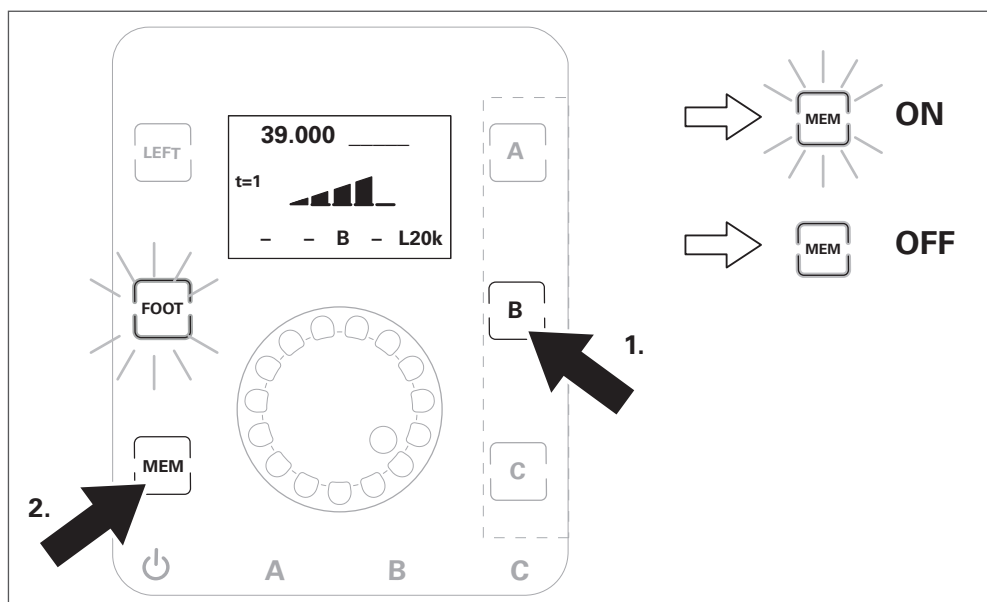

Fig. 19

The function of the MEM button allows the [FOOT] button switch status (ON or OFF) to be stored individually for each motor channel.

- To do this, set the **MEM foot pedal** parameter to "ON" in the "Options" menu.

## 8 Main menu overview

Submenu level 1	Submenu level 2	Parameter	Description	Page
Sprache/Language		Deutsch	Sets the system language	Page 16
		English		
		Francais		
		Cestina		
		Espanol		
		Italiano		
		Slovensky		
		Türce		
U-Info	Operating times		Displays the allocation of the channel buffers and the operating hours of the motors	Page 24
	Events		Displays a list of the following contents: <ul style="list-style-type: none"> <li>• Overload messages that occurred per motor type</li> <li>• Error messages that occurred per error type</li> </ul>	
	Version		Displays the software and hardware versions of the unit components and the total runtime of the unit	
Options	Timer	Off	Disables the "Timer" option	Page 25
		1 – 120	Sets the time in minutes until the timer stops the motor	
	HP-MultiSwitch	On/Off	Activates/deactivates the "HP MultiSwitch" option	Page 25
	Limit Left rpm	On/Off	Activates/deactivates the "Limit Left rpm" option	Page 26
	MEM foot pedal	On/Off	Activates/deactivates the "Memory foot pedal" option	Page 26
	Diagnostics screen	On/Off	Activates/deactivates the "Diagnostics screen" option	Page 28
	Ext. input	Pedal 1		For use of joke foot pedal, item no. 0011002
Pedal 2			For use with standardised foot pedals, e.g. 0 011 003	
PLC control			For use with units with the "PLC Control" hardware option	
Interfaces	Firmware update		To start a firmware update; only after consultation with joke Service	Page 38
	PLC control		Configures the external control of units with the "PLC Control" hardware option The menu can only be accessed if PLC mode is activated.	Page 33
	Unit reset		Resets the software switches and parameter values to the basic settings	Page 38
	Bearing RunIn		Optional; only after consultation with joke Service	Page 38

## 9 Opening the main menu and navigating within menus

► Open the main menu. To do this, press the rotary control/rotary encoder twice.

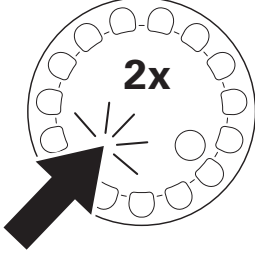
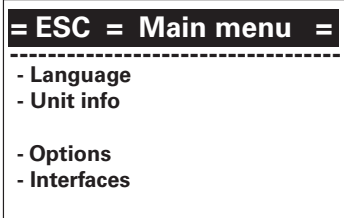
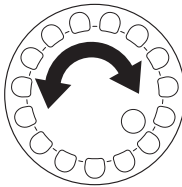
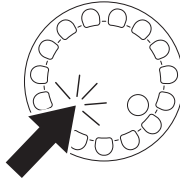
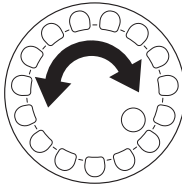
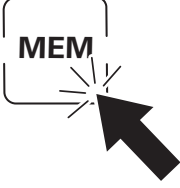
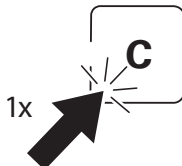
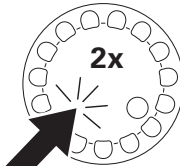
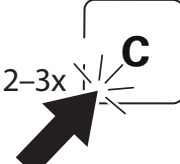
Action	Display		
 <p>Open main menu</p>			
	<p><b>Select a submenu or parameter:</b></p> <p>► Turn the rotary control/rotary encoder. The selection bar moves up or down one position.</p>		<p><b>Display the selected menu or activate the selected parameter:</b></p> <p>► Press the rotary control/rotary encoder once.</p>
	<p><b>Change the value of the activated parameter:</b></p> <p>► Turn the rotary control/rotary encoder. The parameter value is increased or decreased.</p>		<p><b>Save the selected setting:</b></p> <p>► Press the [MEM] button.</p>
	<p><b>Return to the previous menu level:</b></p> <p>1st method</p> <p>► Press the motor button [C] with ESC function once.</p> <p>2nd method</p> <p>► Select "ESC = [Menu Name]" at the top of the menu.</p>	  	<p><b>Exiting the menu and returning to the main screen</b></p> <p>1st method</p> <p>► Press the rotary control/rotary encoder 2 times.</p> <p>2nd method</p> <p>► At the top level of the main menu, select "ESC = main menu".</p> <p>3rd method</p> <p>► Depending on the menu level, press the motor button [C] with ESC function 2 or 3 times.</p>

## 10 Displaying information about the unit

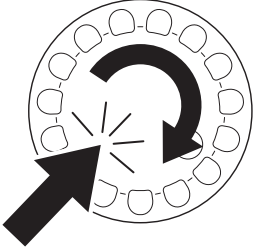
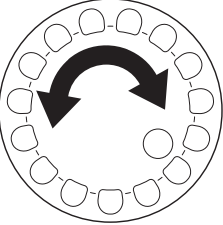
Action	Display
 <p>Select the type of information</p>	<pre> = ESC = U-INFO = ----- - Operating times - Events - Version [C]=ESC           </pre>
 <p>View the relevant unit information</p> <p><b>Note</b></p> <p>You can scroll through the respective submenus, and the adjacent figures show an example section for each case.</p>	<pre> = ESC = INFO-MOT = ----- [Mem] A = X.XXX/R [Mem] B = XX.XXX/L [Mem] C = XX % /L --      -- [h] XXX = X,X [C]=ESC           </pre> <p>Order of displays:</p> <ul style="list-style-type: none"> <li>- Channel memory allocation</li> <li>- Motor operating hours</li> </ul>
	<pre> = ESC = INFO-EVENTS = ----- [BLDC] XXXX = X [DC] XXXX = X --      -- [Err] E 1 = X [Err] E 2 = X [C]=ESC           </pre> <p>Order of displays:</p> <ul style="list-style-type: none"> <li>- Motor overload messages</li> <li>- Error messages after error code</li> </ul>
	<pre> = ESC = INFO-VERS = ----- SW-Display: V xxx HW-Display: XXXX SW-Power : V xxx HW-Power : XXXX Device : XX,X h [C]=ESC           </pre>



## 11 Unit functions in the "Options" menu

### 11.1 Setting the "Timer" option

The "Timer" option allows you to set a timer. As soon as a motor runs without a load, a timer starts and switches the motor off once the set time has elapsed. The factory setting is one minute.

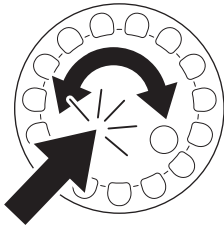
Action	Display
 <p>Set timer</p>	<div style="border: 1px solid black; padding: 5px; width: fit-content;"> <p><b>= ESC = OPTIONS =</b></p> <hr/> <p><b>Timer (minutes) = XX</b></p> <p>_____ = ____</p> <p>_____ = ____</p> <p>_____ = ____</p> <p>_____ = ____</p> <p>[MEM]=Save [C]=ESC</p> </div> <p>Time in minutes</p> <p>Possible values: OFF to 120 min.</p>

### 11.2 Switching the direction of rotation on and off via the handpiece

To avoid incorrect conditions for working with certain tools, the rotation direction change can be deactivated on the handpiece.

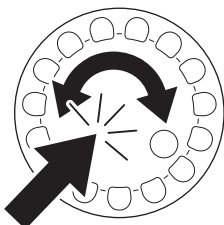
Action	Display
 <p>Activate/deactivate the function</p>	<div style="border: 1px solid black; padding: 5px; width: fit-content;"> <p><b>= ESC = OPTIONS =</b></p> <hr/> <p><b>HP-Multiswitch = XX</b></p> <p>_____ = ____</p> <p>_____ = ____</p> <p>_____ = ____</p> <p>_____ = ____</p> <p>[MEM]=Save [C]=ESC</p> </div> <p>Activate/deactivate the function</p> <p>Possible values: OFF/ON</p>

### 11.3 Adjusting the speed limiter in anti-clockwise rotation

To prevent incorrect settings for working with certain tools, the speed can be additionally limited in anti-clockwise rotation.

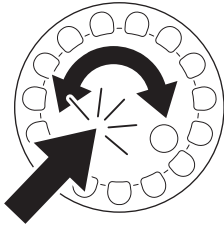
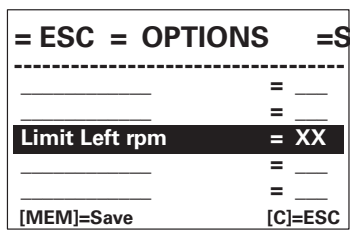
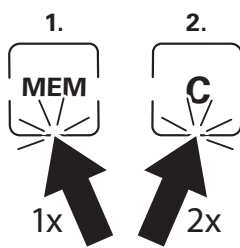
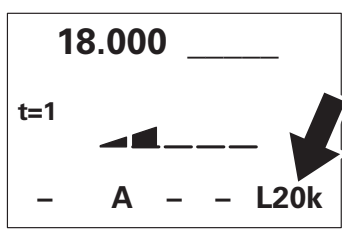
Action	Display
 <p>Set the maximum speed</p>	 <p>Speed in rpm Possible values: OFF - 30 000 rpm</p>
 <p>Save and exit</p>	 <p>Display of speed limit in anti-clockwise rotation</p>

### 11.4 Activating the “Foot pedal memory” (MEM foot pedal) option

When you activate the “Foot pedal memory” option, the unit remembers the switching status of the [FOOT] button individually for each motor channel. When you change the motor channel, the switch status of the [FOOT] button is loaded for the selected motor channel.



#### Note

You can save the switch states of the [FOOT] button with the Memory function (MEM). In this way, the switching states are not lost during a unit restart (see chapter 3.1 on page 8).

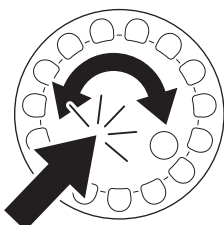
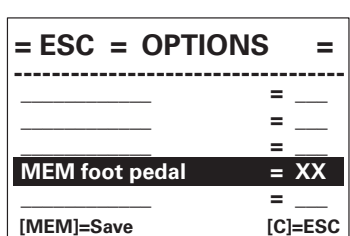
Action	Display
 <p>Activate/deactivate the function</p>	 <p>Activate/deactivate the function Possible values: OFF/ON</p>

## 11.5 Activating the “Diagnostics screen” option

To access the diagnostics screen, you must first activate the “Diagnostics screen” function in the “Options” menu. As long as the “Diagnostics screen” option is activated, you can switch directly between the main display and the diagnostic screen.



### Note

The “Diagnostics screen” option is deactivated after each unit restart and must be re-activated if needed.

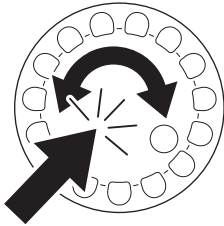
Action	Display														
 <p>Activate/deactivate the function</p>	<table border="1"> <tr> <td colspan="2" style="text-align: center;"><b>= ESC = OPTIONS =</b></td> </tr> <tr> <td>-----</td> <td style="text-align: right;">=</td> </tr> <tr> <td>-----</td> <td style="text-align: right;">=</td> </tr> <tr> <td>-----</td> <td style="text-align: right;">=</td> </tr> <tr> <td>-----</td> <td style="text-align: right;">=</td> </tr> <tr> <td><b>Diagnostics screen</b></td> <td style="text-align: right;"><b>= XX</b></td> </tr> <tr> <td>[MEM]=Save</td> <td style="text-align: right;">[C]=ESC</td> </tr> </table> <p style="text-align: right;"><b>Activate/deactivate the function</b> Possible values: OFF/ON</p>	<b>= ESC = OPTIONS =</b>		-----	=	-----	=	-----	=	-----	=	<b>Diagnostics screen</b>	<b>= XX</b>	[MEM]=Save	[C]=ESC
<b>= ESC = OPTIONS =</b>															
-----	=														
-----	=														
-----	=														
-----	=														
<b>Diagnostics screen</b>	<b>= XX</b>														
[MEM]=Save	[C]=ESC														

To access the diagnostics screen:

- ▶ Activate the “Diagnostics screen” function (“Diagnostics screen = ON”).
- ▶ Press the rotary control/rotary encoder to toggle between the main display and the diagnostics screen.

### 11.5.1 Overview of “Diagnostics Screen”

The diagnostics screen displays the following operating data.

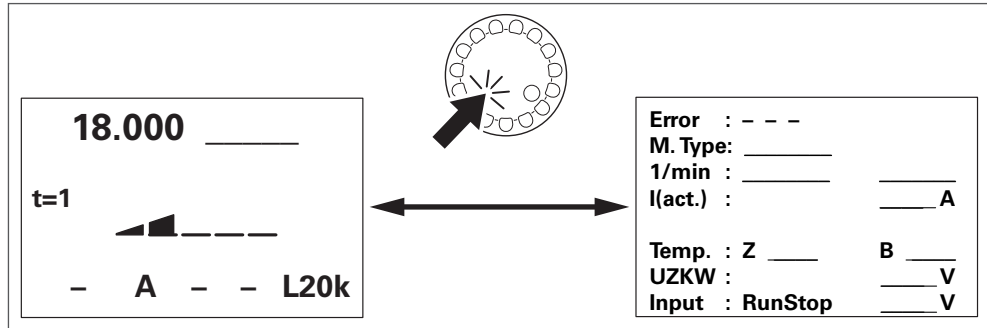

Fig. 20

Error	Displays error codes of active fault messages
M.Type	Displays the type of motor connected to the active motor channel
1 rpm	Displays the maximum speed and the set speed for the motor in the active motor channel
I (act.)	Displays the current motor current in A
Temp.	Displays the current temperatures on the unit's boards <ul style="list-style-type: none"> <li>• Z = DC auxiliary board</li> <li>• B = BLDC board</li> </ul>
Input	<ul style="list-style-type: none"> <li>• Displays the type of configuration type selected for the input: <ul style="list-style-type: none"> <li>• “Run/STP” = digital start-stop circuit with setpoint SP1 or SP2</li> <li>• “0 – 5 V” = motor control via analogue setpoint</li> <li>• “0 – 10 V” = motor control via analogue setpoint</li> </ul> </li> <li>• Displays the setpoint value in V</li> </ul> <p>To configure the input: see chapter 13.5 “Connecting the PLC” on page 36.</p>

## 11.6 “External control input” option (ext. input) assign

In the “Options” menu, you can use the **Ext. input** parameter to specify the foot pedal type or PLC operating mode for controlling the unit.

- “Ext. input = Foot ped. 1”

The **Ext. input** parameter is preset under the “Footped. 2” option on delivery. Select this option if you want to use the joke foot pedal with 4-pin diode plug (item no. 0011002).

- “Ext. input = Foot ped. 2”

This option sets the foot controller input of the controller to a standardised input signal from 0 V to 5 V. Select this setting to use standardised foot pedals.

If you select this option, you will not be able to use the joke foot pedal with 4-pin diode plug (item no. 0011002). Alternative item no.: 0 011 003.

- “Ext. input = PLCcontrol”

If you select this option, operation with a foot pedal is not possible. This option switches the control of the unit from handheld control to PLC for automated control (see chapter 13 “PLC operating mode for external motor control (ENESKAmicro 600 PLC only)” on page 33).

**Note**

You can only select this option for units with the extension “PLC Control”.

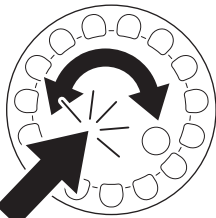

Action	Display
 <p>Select the type of foot pedal or PLC mode</p>	<div style="border: 1px solid black; padding: 5px; width: fit-content;"> <p><b>= ESC = OPTIONS =</b></p> <hr style="border-top: 1px dashed black;"/> <p><b>Ext. input. = XX</b></p> <p>[MEM]=Save [C]=ESC</p> </div> <p>Possible values:</p> <ul style="list-style-type: none"> <li>- Pedal 1 (for joke foot pedal 0011002)</li> <li>- Pedal 2 (for standardised input signal 0 – 5 V)</li> <li>- PLCcontrol (for PLC mode)</li> </ul>

## 12 Using the foot pedal on the external input

A foot pedal can be used to control the speed of the tool using your foot during operation. Variable speeds between 0 and the set speed can be used this way.

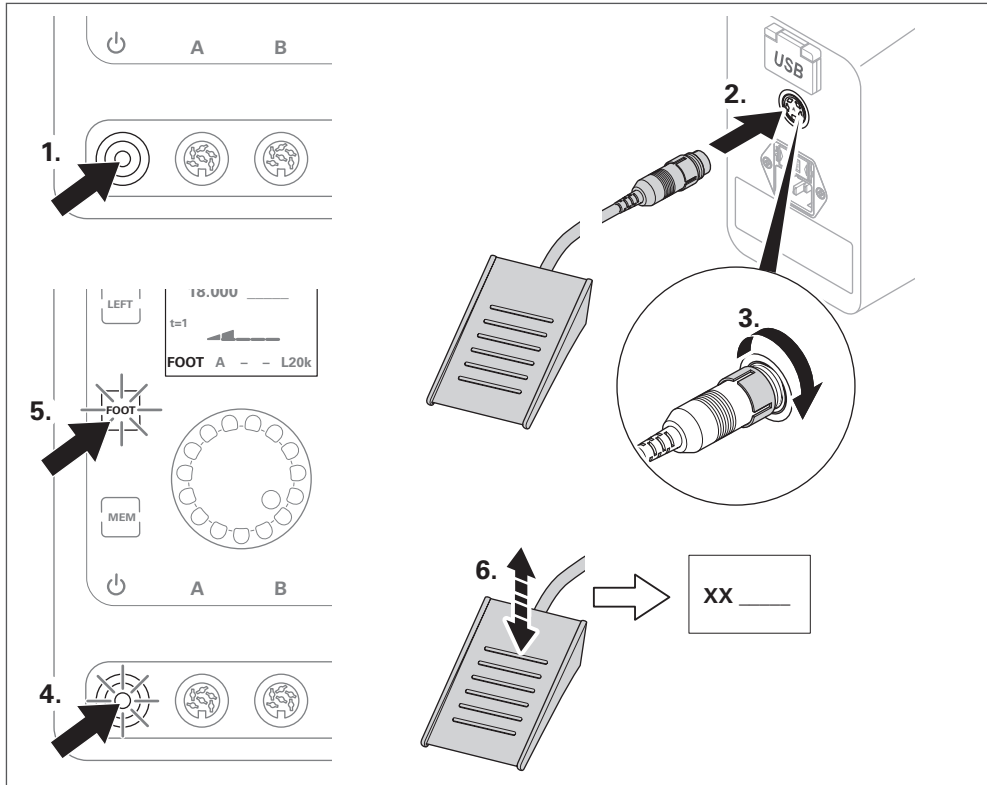

Fig. 21

When the foot pedal is connected, the lower display line shows "FOOT".



### Note

Units with a module for external control (PLC control) are supplied with a 8-pin IO industrial plug. The foot pedal must be equipped with the appropriate M12 industrial plug.

## 12.1 Fixing the speed of the foot pedal (FIX-it)

If you use the FIX-it function, you can fix the speed of the motor while working with the foot pedal. Once the FIX-it function is activated, you can release the foot pedal and the motor continues to rotate at the fixed speed.

You can activate the FIX-it function using the control unit buttons or the ON/OFF button on the handpiece.

### Use the FIX-it function via the control unit

- ▶ Press and hold the foot pedal to control the motor.
- ▶ Activate the FIX-it function. To do this, press the motor button of the desired motor or press the [FOOT] button.
- ▶ Take your foot off the foot pedal.

As long as the FIX-it function is activated, the [FOOT] button flashes and the display shows "FIX".

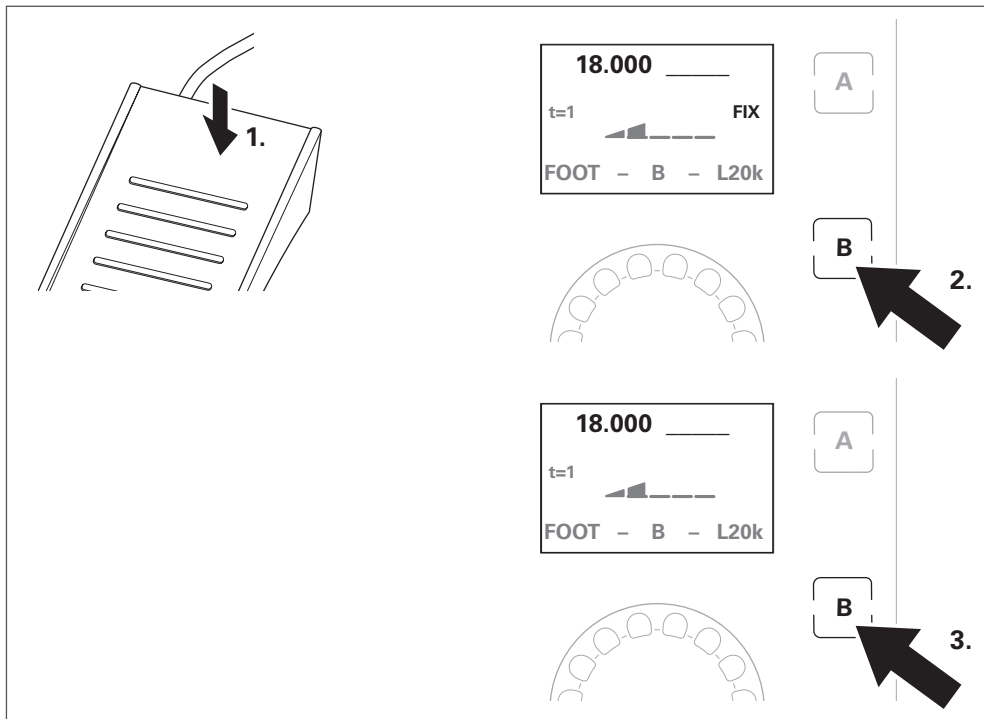

Fig. 22

### Use the FIX-it function via the handpiece

- ▶ Press and hold the foot pedal to control the motor.
- ▶ Activate the FIX-it function. To do this, press the ON/OFF button on the handpiece.
- ▶ Take your foot off the foot pedal.

As long as the FIX-it function is activated, the [FOOT] button flashes and the display shows "FIX".

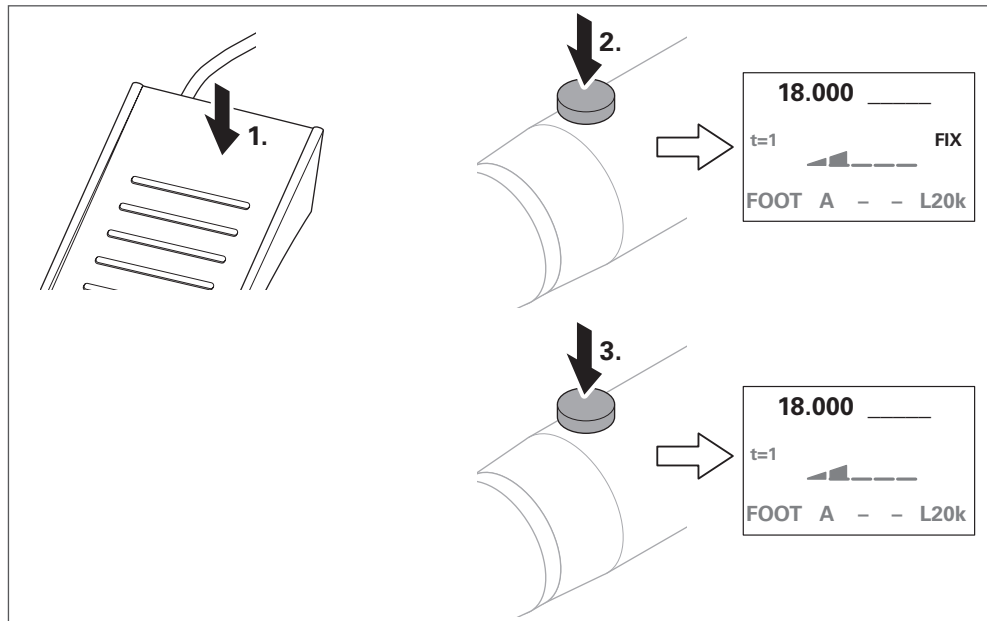

Fig. 23

### Deactivating the FIX-it function

Depending on how you deactivate the FIX-it function, the motor is also switched off or the motor remains active.

To deactivate the FIX-it function and switch off the motor:

- ▶ Press the motor button or the ON/OFF button of the handpiece.

The motor is switched off and the motor button flashes.

To deactivate the FIX-it function without switching off the motor:

- ▶ Press the foot pedal or press the [FOOT] button.

The motor remains active and the motor button lights up.



## 13 PLC operating mode for external motor control (ENESKAmicro 600 PLC only)

The external control must not exceed the load limits of the unit, which are customary in handheld operation in terms of time and power transmission.

The user is responsible for unit operation via external control.

In PLC mode, the manual operating functions via the handpiece as well as the setting options for speed and direction of rotation via the control unit are deactivated.



### Note

Operation with an external PLC controller is only possible with the ENESKAmicro 600 PLC control unit.

### 13.1 Keys in PLC mode

As long as the unit is automatically controlled via PLC, the unit's buttons light up to signal the external control (Fig. 24).

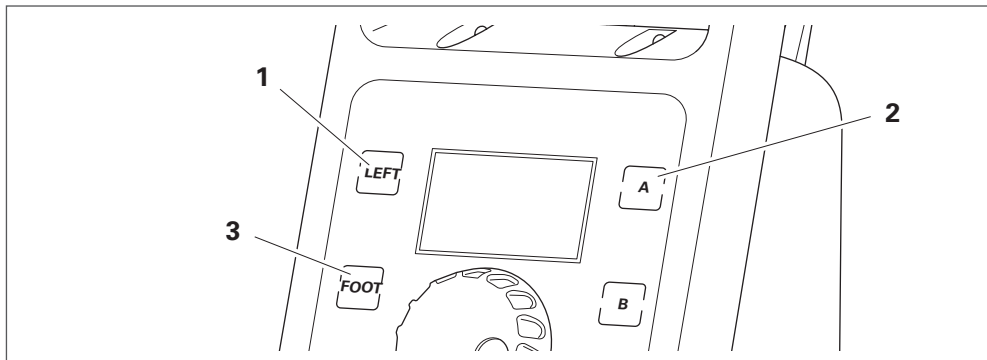

Fig. 24

1	[Left] key	Lights up during anti-clockwise rotation
2	Motor button [A], [B], [C]	The motor button of the selected channel flashes.
3	[FOOT] button	Lights up while the motor is running

### 13.2 Main display in PLC mode

As long as the unit is automatically controlled via PLC, the main display shows the following information:

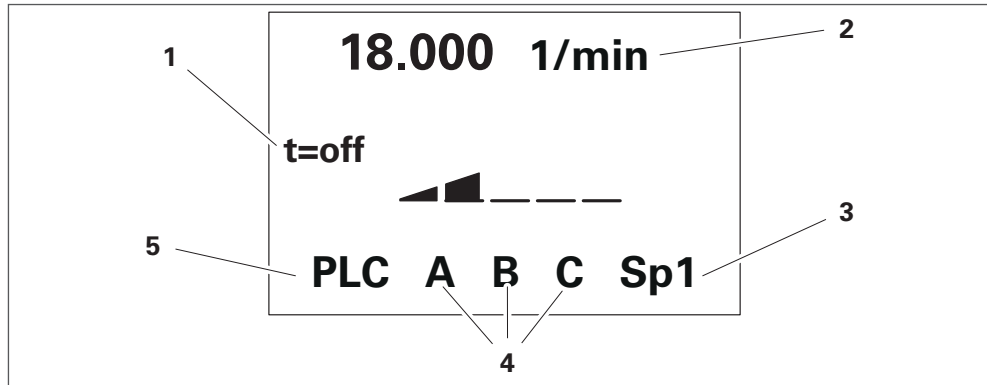

Fig. 25

1	Display of timer function	Indicates that the timer function is deactivated The timer function cannot be used in PLC mode.
2	Speed display	Displays the setpoint speed and the actual speed
3	Speed parameters	If you have specified setpoint speeds for "run/stop" operation, the switched speed "SP1" ( <b>speed 1</b> parameter) or "SP2" ( <b>speed 2</b> parameter) is displayed. If you have set the speed manually, the set measuring range "0 – 5 V" or "0 – 10 V" is displayed.
4	Motor channel A, B, C	Displays the connected motor channels
5	"PLC" operating mode	Indicates that the unit is operating in PLC mode

- ▶ In the main display, press the rotary control/rotary encoder to switch between the main display and the diagnostics screen (see chapter 11.5.1 "Overview of "Diagnostics Screen"" on page 28).

### 13.3 Activating PLC operating mode

- ▶ Open the "Options" menu.
- ▶ Set the **Ext. input** parameter to the value "PLCcontrol".

As soon as PLC mode is activated, the "PLC Control" menu opens automatically. In this menu, you can configure the PLC mode (see chapter 13.4 on page 35).

As long as PLC mode is activated, you can open the "PLC Control" menu again at any time via the "Interfaces" menu.

## 13.4 Parametrising the PLC

In the “PLC Control” menu, you can specify whether the superordinate controller should move to the motor in an analogue or contact-controlled manner. You can only access this menu as long as PLC mode is activated.

### 13.4.1 Activate “Run/stop” mode and specify the set speeds

With the “Run/stop” option for contact-controlled control, you can specify 2 set speeds for each motor channel. You must specify these set speeds individually for each motor channel (A, B, C). The minimum values and maximum values are limited to the permissible value range of the connected joke motor.

- ▶ Connect the desired motors.
- ▶ Open the “PLC Control” menu.
- ▶ Carry out the required parameter settings.

Parameter	Possible values	Function
Channel selection	<ul style="list-style-type: none"> <li>• AB</li> <li>• AC</li> <li>• BC</li> </ul>	For 2 connected motors, specifies between which two motor channels can be switched (see chapter 13.5 on page 36)
Ext. input	Run/stop	Activates contact-controlled activation

To set the parameters **speed 1** and **speed 2** for the desired motor channel:

- ▶ Select the desired motor channel in the “PLC Control” menu:
  - Motor channel A
  - Motor channel B
  - Motor channel C



#### Attention

- ▶ Set the desired speeds for the **Speed 1** and **Speed 2** parameters. Observe the permissible speeds of the handpieces, the attachments used and the tools. Limit your setting to the lowest permissible maximum speed.



#### Note

If the permitted minimum or maximum speed is exceeded or not reached, an error message is shown in the display, which prevents release during operation.

### 13.4.2 Activating analogue control

- ▶ Ensure that the desired motors are connected.
- ▶ Open the “PLC Control” menu.
- ▶ Carry out the required parameter settings.

Parameter	Possible values	Function
Channel selection	<ul style="list-style-type: none"> <li>• AB</li> <li>• AC</li> <li>• BC</li> </ul>	For 2 connected motors, specifies between which two motor channels can be switched (see chapter 13.5 on page 36)
Ext. input	<ul style="list-style-type: none"> <li>• 0 – 5 [V]</li> <li>• 0 – 10 [V]</li> </ul>	Possible measuring ranges



#### Attention!

If you exceed the voltage range limits, the input may be damaged beyond repair. The analogue measuring range input “AIN” is protected for a short time up to a voltage of 19 V.

- ▶ Operate in a voltage range of 0 V to a maximum of 12 V.

## 13.5 Connecting the PLC

You can control the unit via 4 inputs and 1 output. The connection to a superordinate controller must be carried out by an electrician.

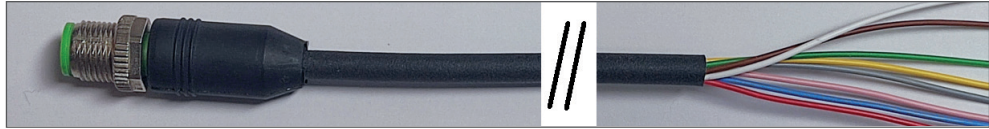

Fig. 26

► For the correct connection of the inputs, observe the following circuit diagram (Fig. 27).



Input	Parameter description
External signal "AIN" (run/stop, 0 – 5 V and 0 – 10 V )	<p>By configuring this input in the "PLC Control" menu, you can select the type of motor control:</p> <ul style="list-style-type: none"> <li>• Contact-controlled in "run/stop" mode</li> <li>• or analogue</li> </ul> <p>If you set the input to "run/stop", you can control the motor via contact control. You can store two set speeds for "run/stop" operation using the <b>Speed 1</b> and <b>Speed 2</b> parameters. You can use the "speed" input to switch to the second set speed (<b>Speed 2</b>).</p> <p>Alternatively, you can specify the speed manually in one of two measuring ranges:</p> <ul style="list-style-type: none"> <li>• 0 – 5 V</li> <li>• 0 – 10 V</li> </ul> <p><b>Attention!</b></p> <p>If you exceed the voltage range limits, the input may be damaged beyond repair. The analogue measuring range input "AIN" is protected for a short time up to a voltage of 19 V.</p> <p>► Operate in a voltage range of 0 to 12 V.</p> <p>Control takes place within the valid speed range of the connected motor. Third-party DC motors are excluded from this.</p>
Speed "SP1 + SP2"	The "Speed" input switches to the second set speed defined for "run/stop" mode ( <b>Speed 2</b> ).
Direction of rotation "R/L"	Without control, a connected motor rotates clockwise. You can switch the direction of rotation to anti-clockwise rotation via the "R/L" input.
Channel selection ("AB", "AC", "BC")	<p>When two motors are connected to the unit, channel selection allows switching to the second motor. To do this, you must specify the desired motor channels in the "PLC Control" menu for the <b>channel selection</b> parameter, which are to be switched between.</p> <p>Possible values:</p> <ul style="list-style-type: none"> <li>• AB</li> <li>• AC</li> <li>• BC</li> </ul> <p>To switch between two motor channels, a running motor must first be stopped.</p>
Output	Function
Open Collector output (OC)	<p>To signal readiness, the OC is switched through to GND.</p> <p>When a green LED with series resistor is connected, this signals readiness. If an error is present or the controller is switched off, the LED remains dark. In this way, you can evaluate the output in your controller.</p> <p>Motor control errors are displayed as text in the display.</p>

**Foot pedal**

**OPTIONS / Ext. input= foot ped.-1**  
Control signal = 5V to 0V  
MR is set automatically

**OPTIONS / Ext. input= foot ped.-1**  
Control signal = 0V to 5V  
MR is set automatically

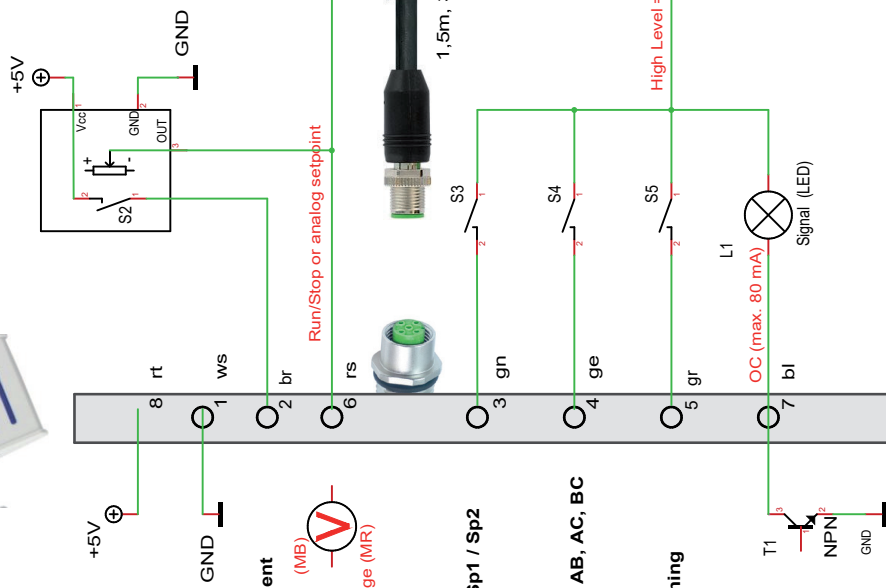

**PLC controlled input**

**OPTIONS/Ext. input= PLC-control**  
Set "Ext.Sig.= PLC-control"  
Set Measuring Range (MR)

**INTERFACES / PLC-control /**  
Ext.Sig.= Measuring Ranges (MR)  
= 0V to 5V  
= 0V to 10V

**INTERFACES / PLC-control /**  
Ext.Sig.= run/stop (L=0V | H=5V)  
Switching contact between pin 6 and 8  
as an option to start the engine  
High level is recognized from 2.5V

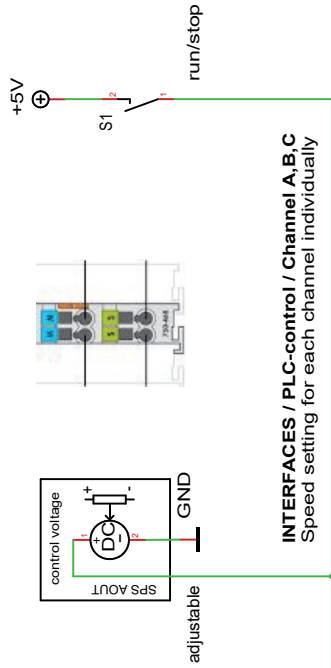

**INTERFACES / PLC-control / Channel A, B, C**  
Speed setting for each channel individually

5V or 10V Signal Input on Pin 6 -> 19V must NOT be exceeded!!  
MR = run/stop  
STOP = 0 to 2,4V  
RUN = 2,5V to 5V

**Connection-example-for-test-operation**

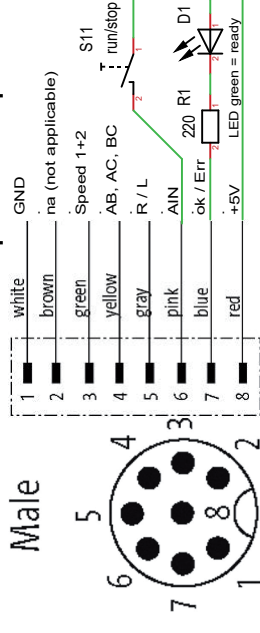

Scale	98,00%	Co.	joke	Drawn by	AR	Page	1 # 1
Change	13.12.2022		AR	Title	PLC-control		
Issue	13.12.2022			Version	v04		
File	micro-PLC-control-v04_T3001			Project	ENESKAmicroNextGen		

*RoS*

Fig. 27



## **14 “Interface” menu access options**

### **14.1 Firmware update**

The firmware of your ENESKAmicro can be updated to the latest version by joke Service. Firmware updates can support new joke motors to meet customer requirements, for example.

### **14.2 PLC control**

This menu is only available if your unit has the optional extension “PLC”. If you set the **Ext. input** parameter “PLCcontrol” in the “Options” menu, the “PLC Control” menu opens (see chapter 13 on page 33).

### **14.3 Bearing RunIn**

This menu is only available if your unit has the optional “Bearing RunIn” extension for an automated bearing infeed of the motors. This extension comes with a separate operating manual.

### **14.4 Reset**

Use the Reset function to reset the unit to the factory default settings. The current unit settings are overwritten with the default settings.

If you have changed parameters, you can use this to restore the default settings of the unit if necessary.

## 15 Fitting the tool and collet



### Warning!

The collet and tool can become hot during operation. You may burn yourself on hot components.  
▶ Let the collet and tool cool down before you work on them.



### Warning!

- ▶ To avoid injury from unintentional rotation of the tool, switch off the control unit before connecting or changing tools
- ▶ Disconnect the unit from the power supply and secure it against being switched back on.



### Note

- ▶ To ensure safe handling: Always insert tools into the collet to the stop, and also adjust the collet for handpieces JEHR 500, JIH 300, JIR 310, JEM 50C, JEM 50C CNC, JIH 40R and JIR 40R.

### 15.1 Changing the tool

- ▶ Switch off the motor and the control unit.
- ▶ Disconnect the motor cable from the motor connector on the control side.
- ▶ When a collet change is necessary see chapter 15.2 "Changing the collet" on page 45.
- ▶ Refer to the following figures to change the tool.

#### 15.1.1 Compact SE, HT60, HT60 SMALL, HT60-XL

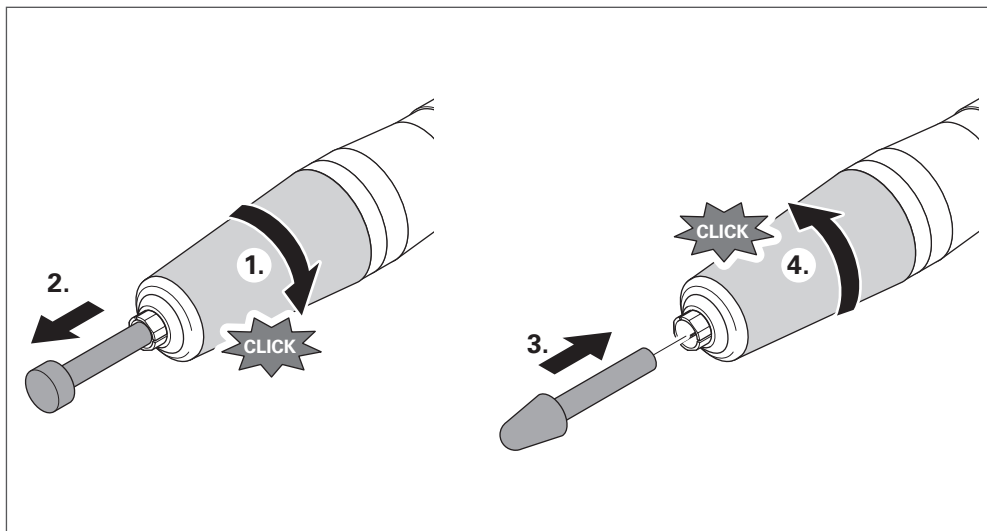

Fig. 28

15.1.2 HT60-D6 (CNC)

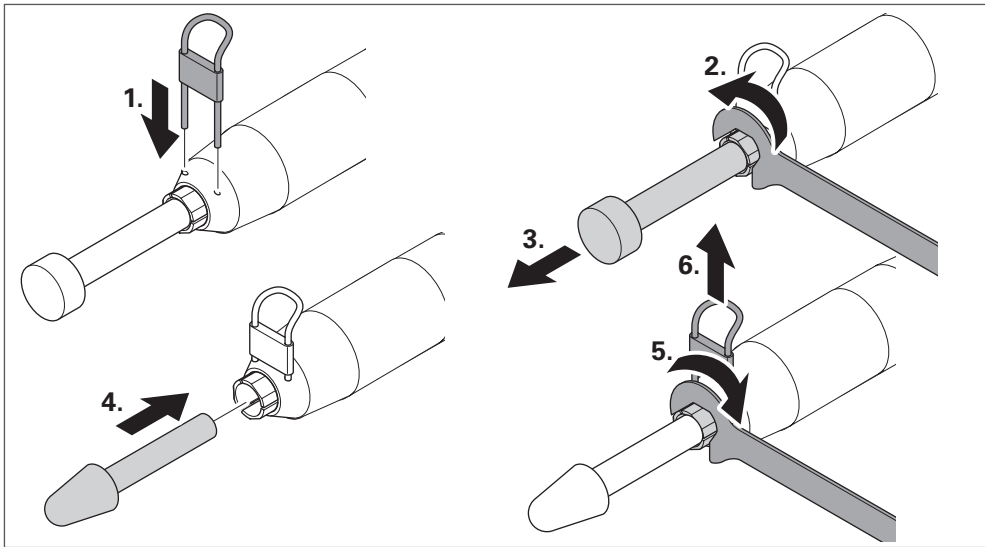

Fig. 29

15.1.3 JEHG 400, JHG 210

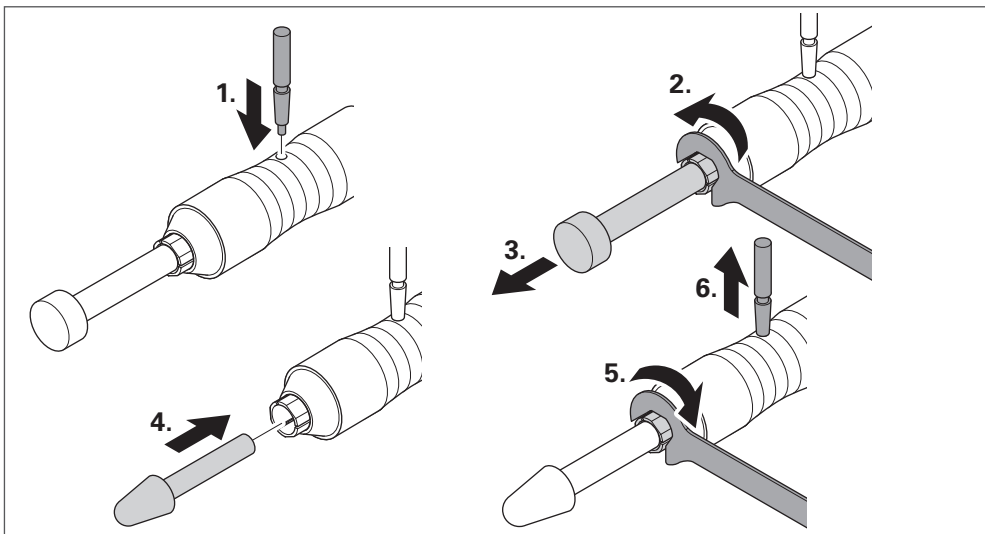

Fig. 30



**15.1.4 JEHR 500, JIR 310, JEM 50C (CNC), JIR 40R,**

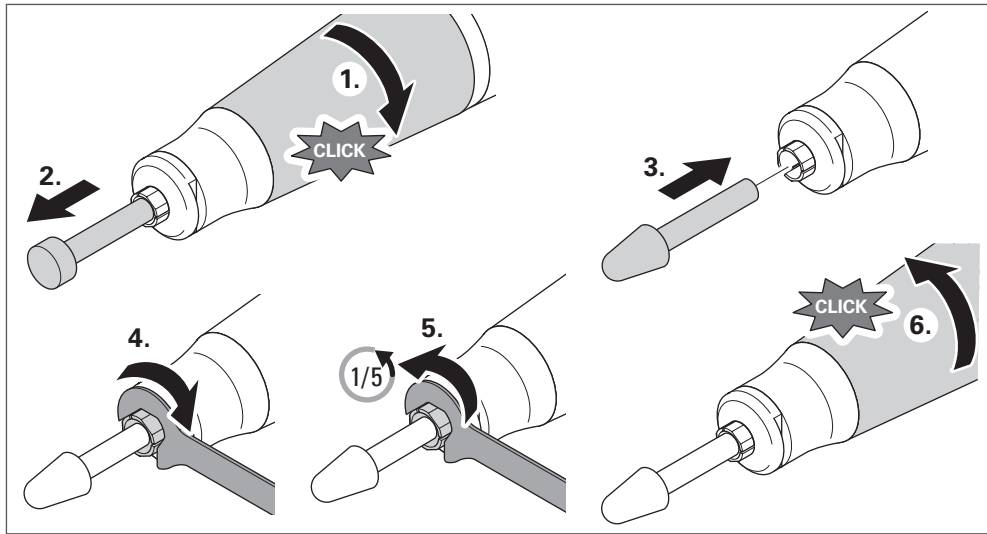

Fig. 31

**15.1.5 JERA 270**

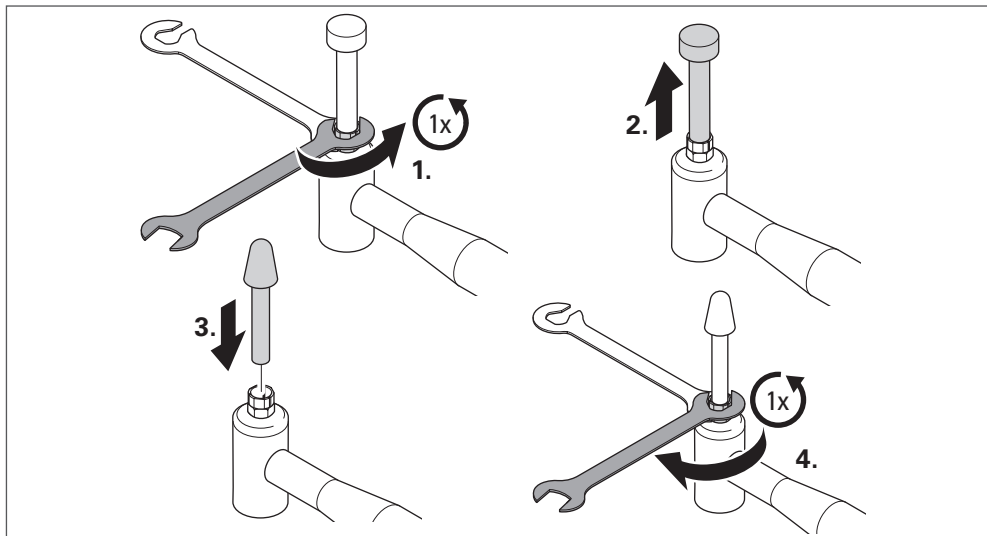

Fig. 32

15.1.6 JBMXLH 40R, JBMH 300 N, JBMLH 40R, JEHG 20R

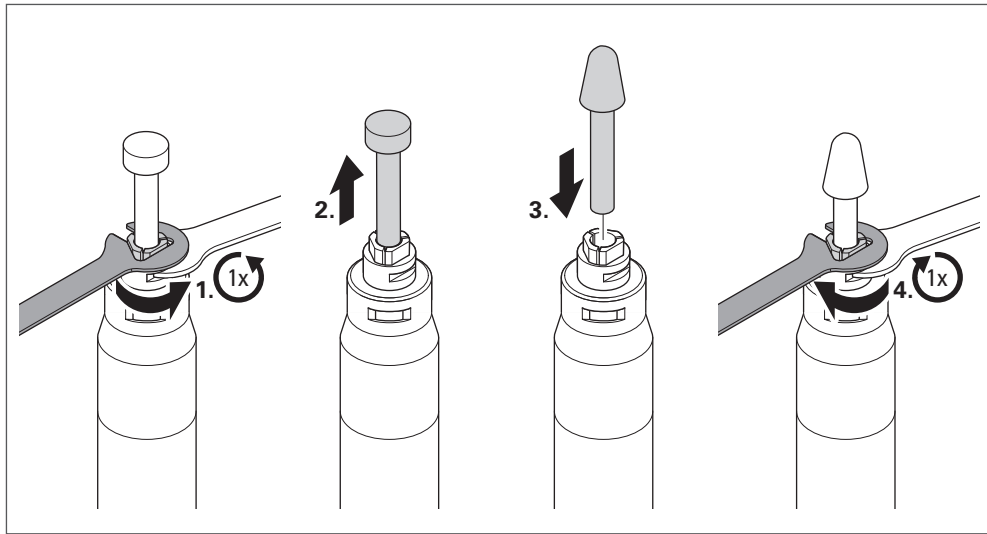

Fig. 33

15.1.7 JERA 270 S

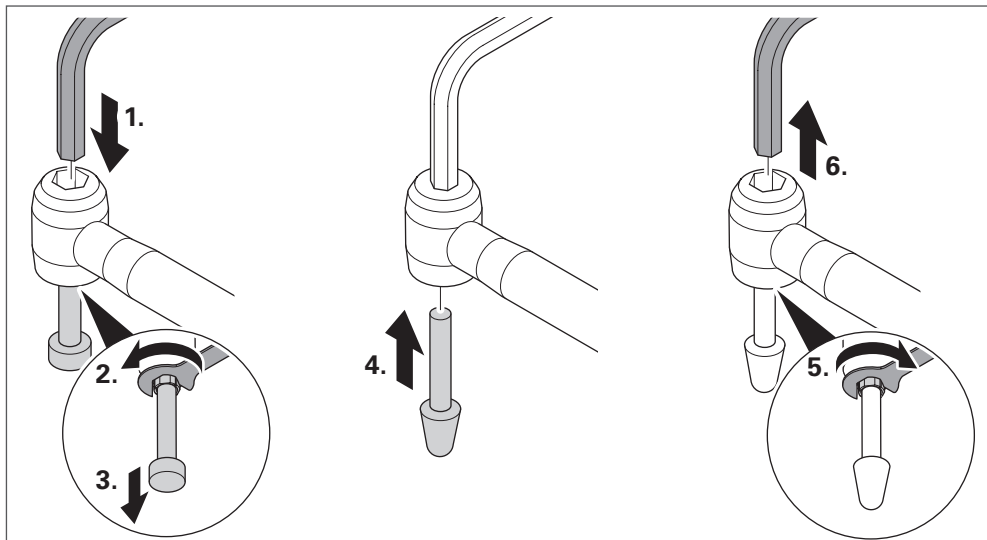

Fig. 34

**15.1.8 JIH 300, JIH 40R**

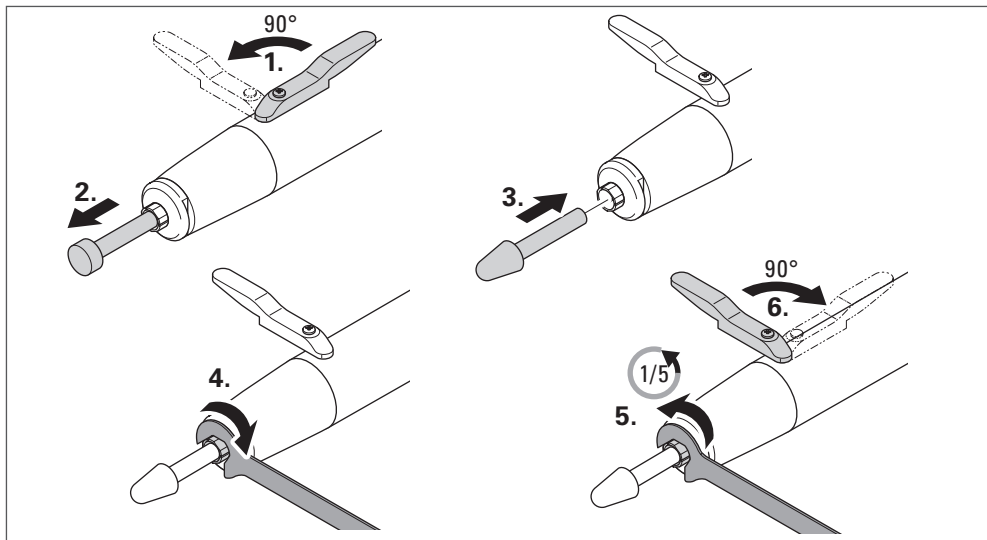

Fig. 35

**15.1.9 JKC 345, JIC 390, JEC 300, WE4-45, WE4-90, JERA 90 20R, JEAH 60 20R**

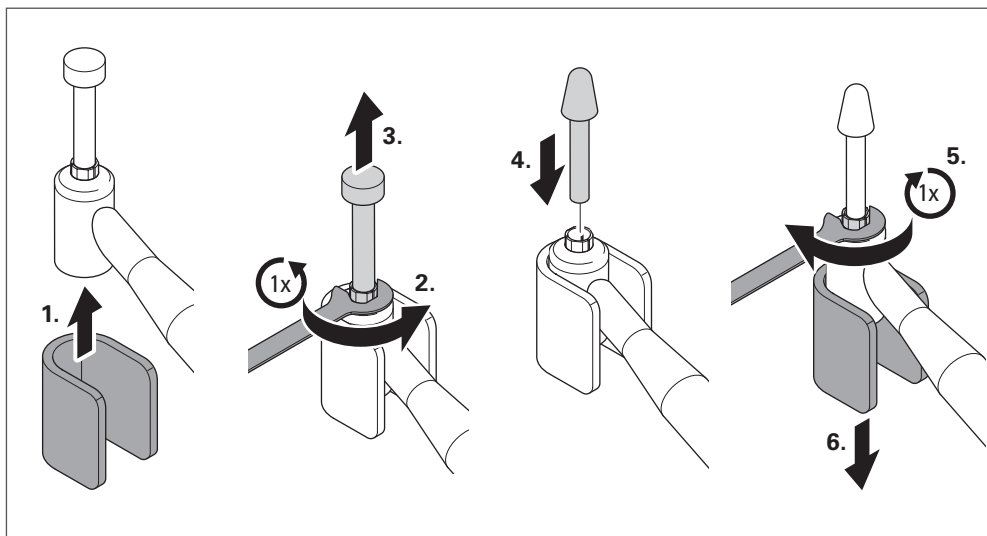

Fig. 36

15.1.10 JMFC 300 S, JMFC 300 M

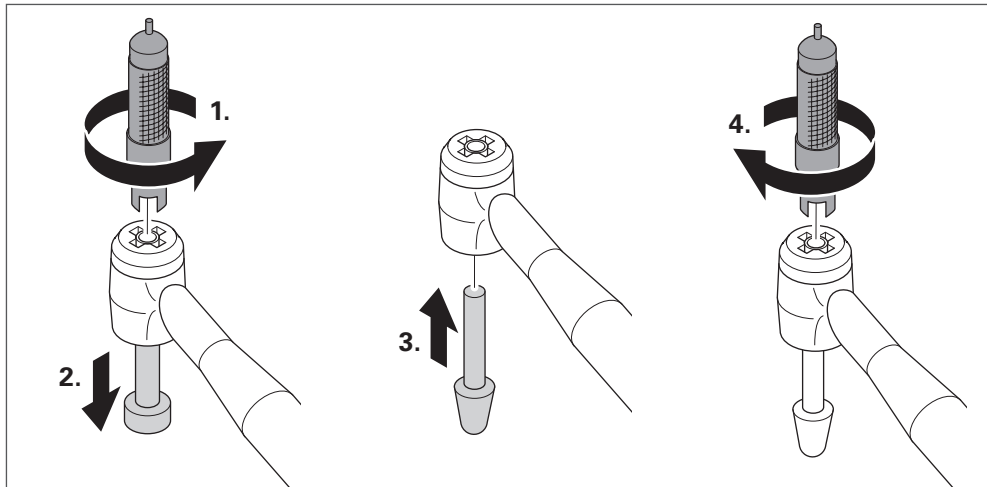

Fig.37

## 15.2 Changing the collet

- ▶ Switch off the motor and the control unit.
- ▶ Disconnect the motor cable from the motor connector on the control side.
- ▶ To change the collet, observe the following figures.

### 15.2.1 COMPACT SE

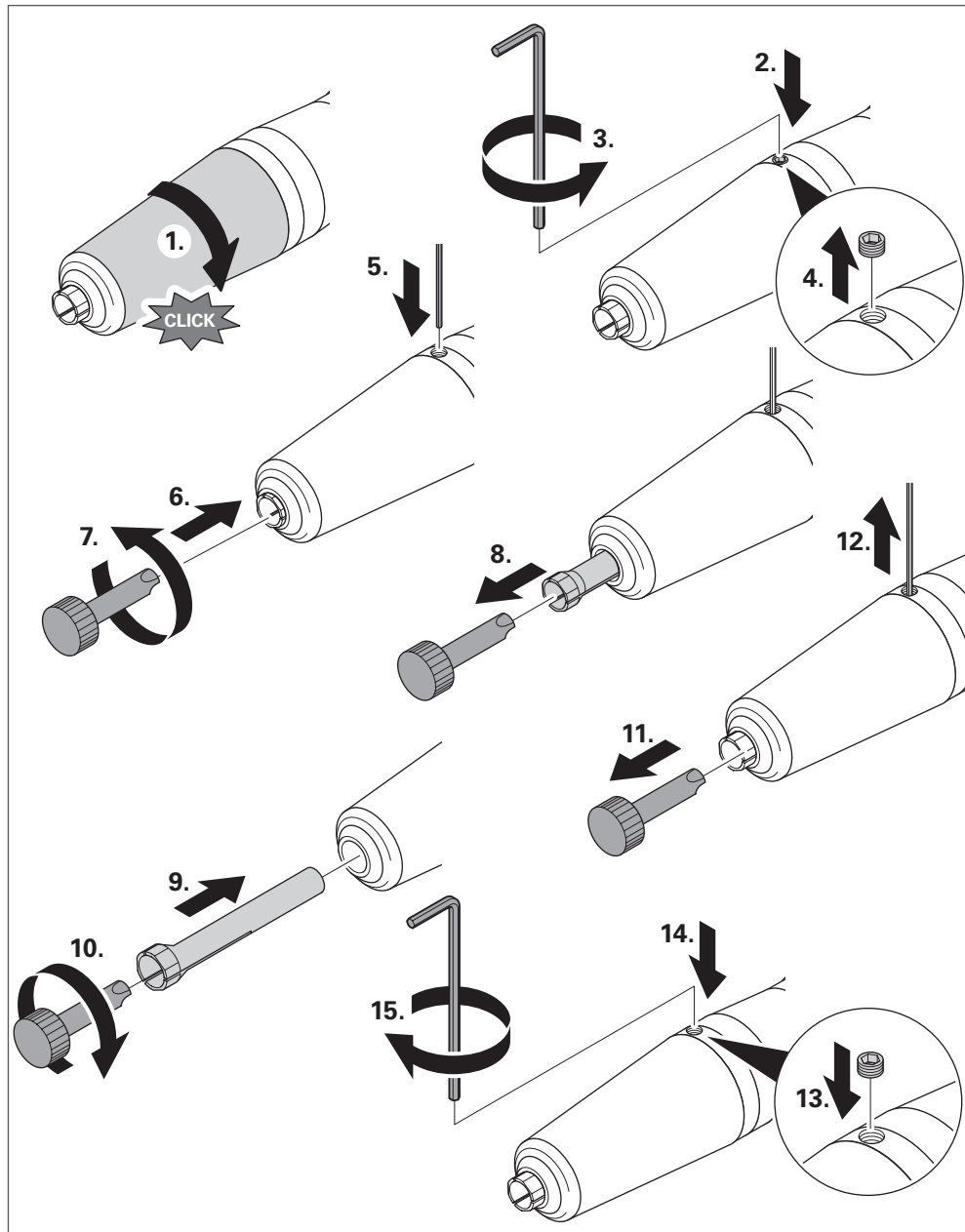

Fig. 38

15.2.2 HT60, HT60-XL

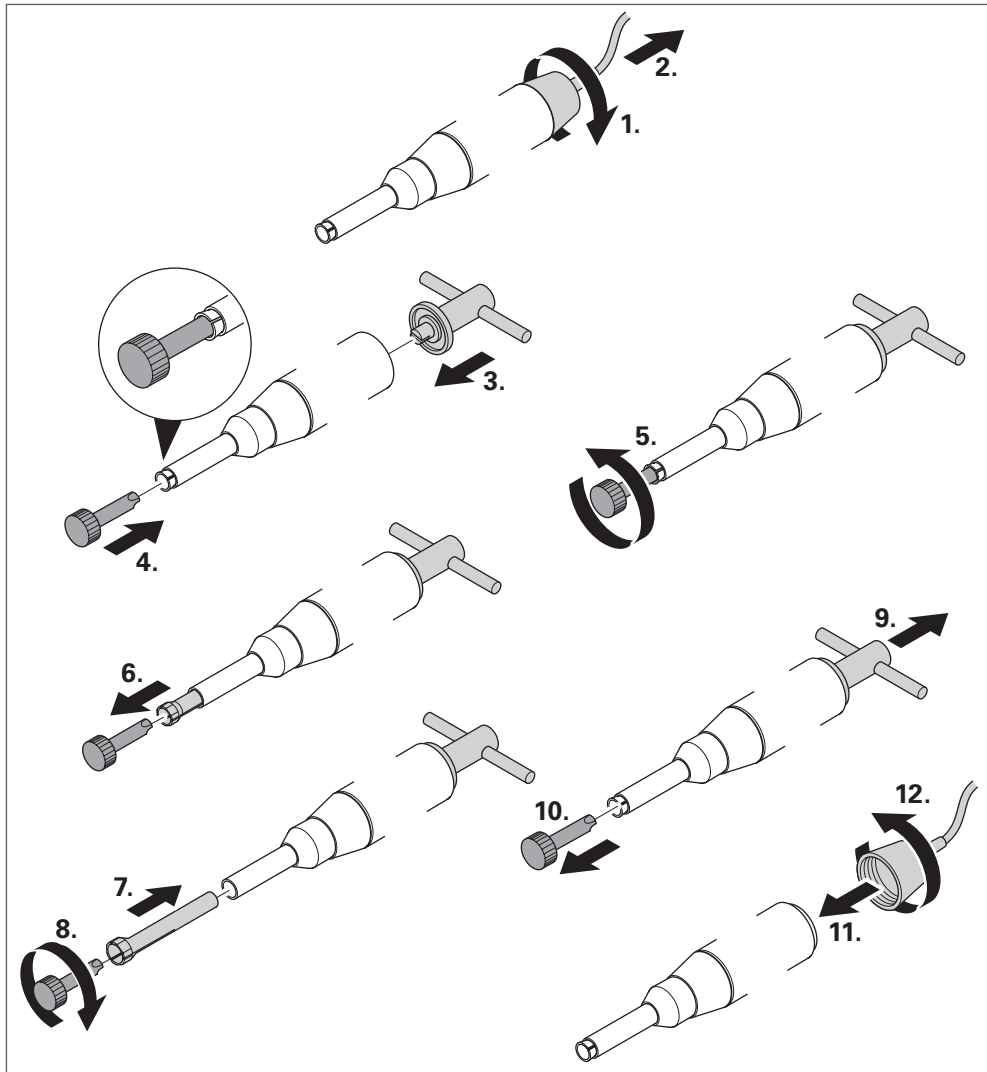

Fig. 39

15.2.3 HT60-D6 (CNC)

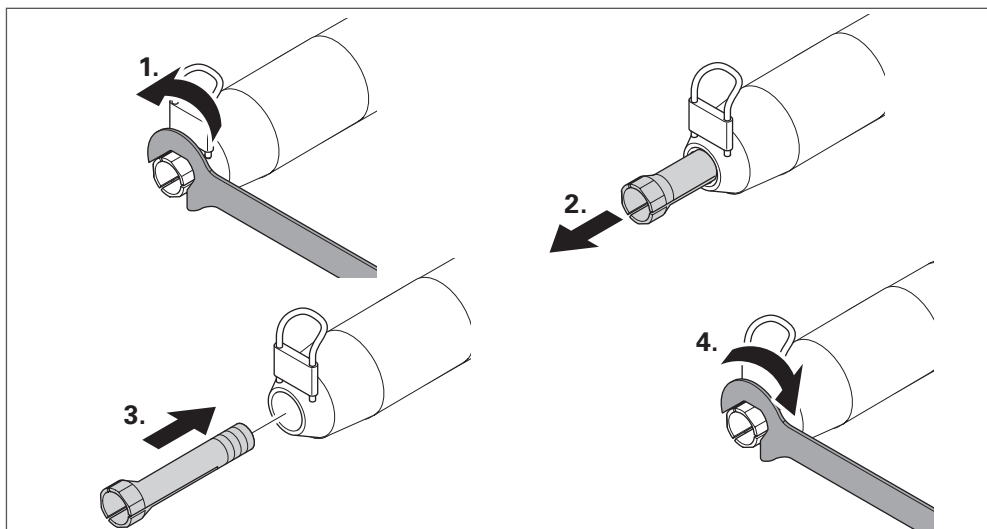

Fig. 40

15.2.4 HT60 SMALL

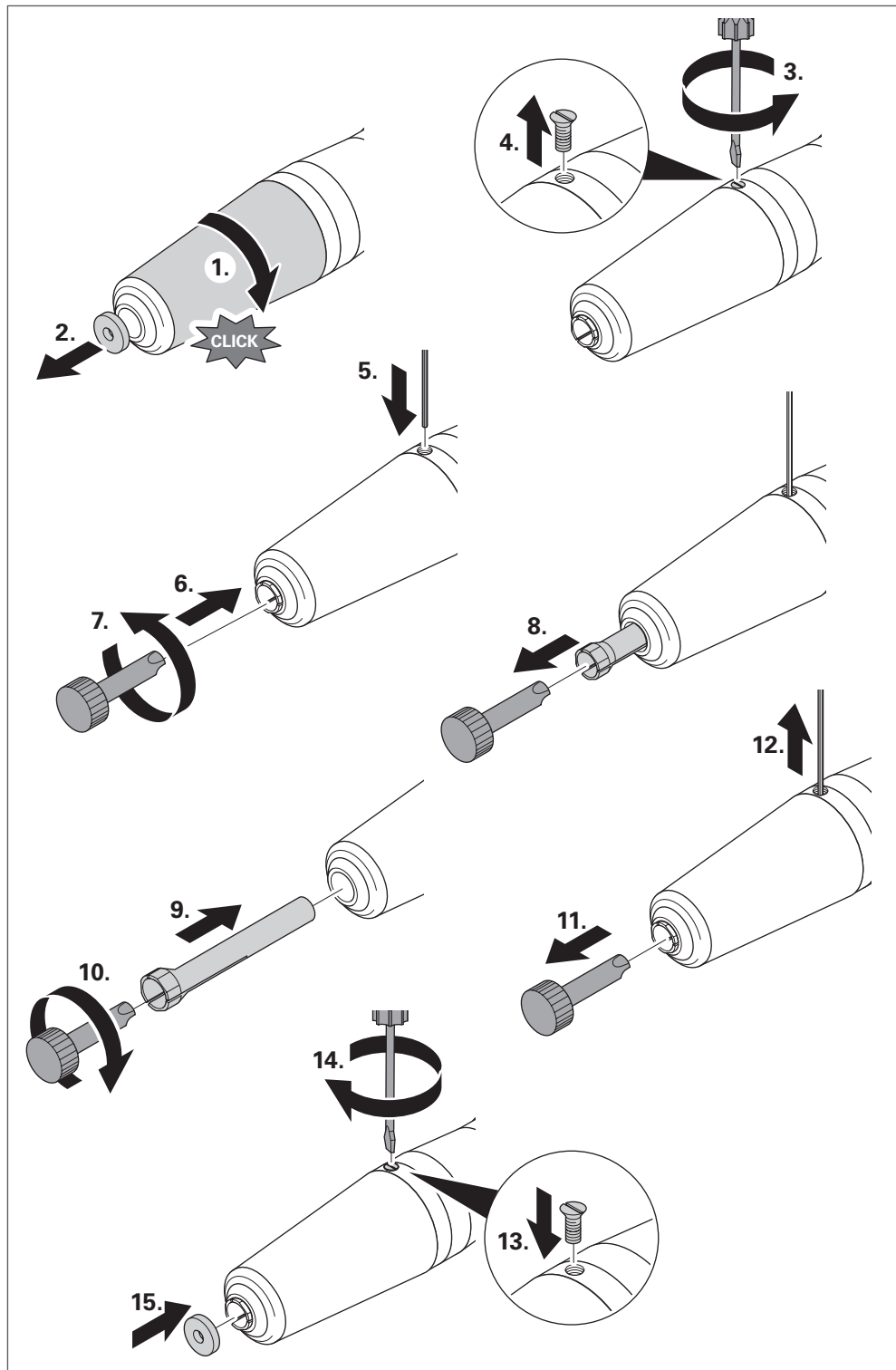

Fig. 41

15.2.5 JEHG 400, JHG 210

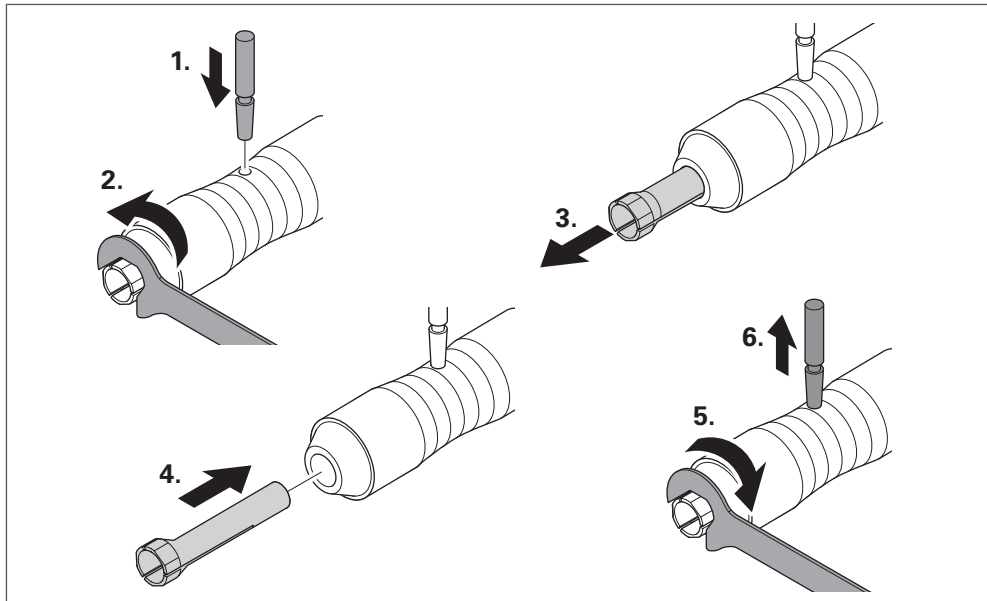

Fig. 42

15.2.6 JEHR 500, JIR 310

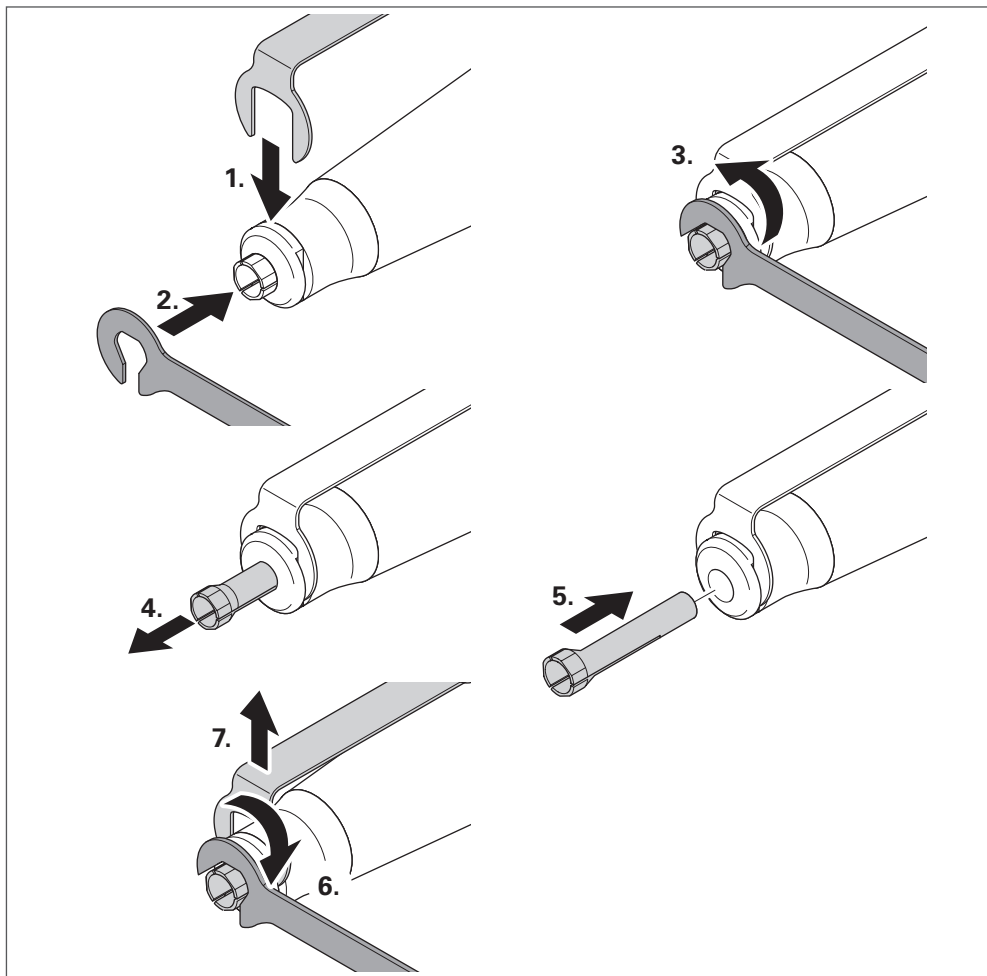

Fig. 43



**15.2.7 JBMXLH 40R, JEM 50C (CNC), JIR 40R, JBMH 300 N, JBMLH 40R, JEHG 20R**

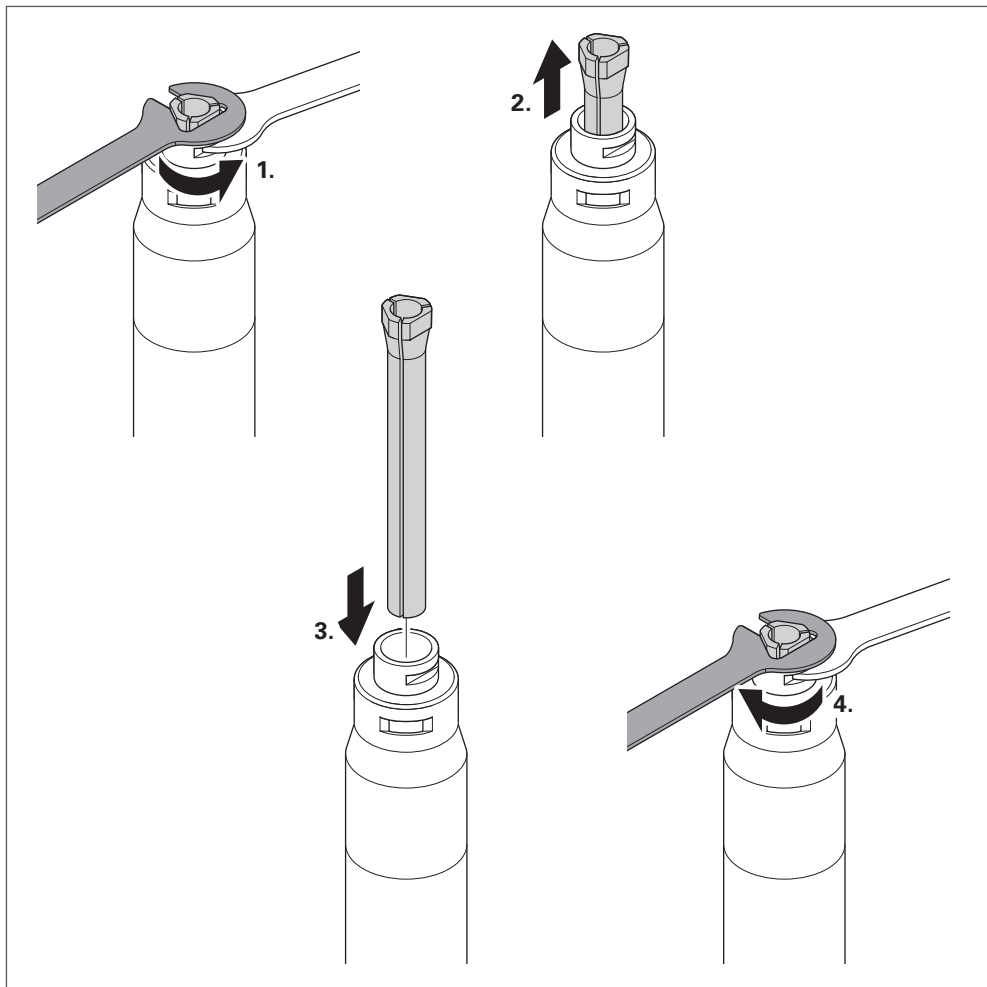

Fig. 44

**15.2.8 JERA 270**

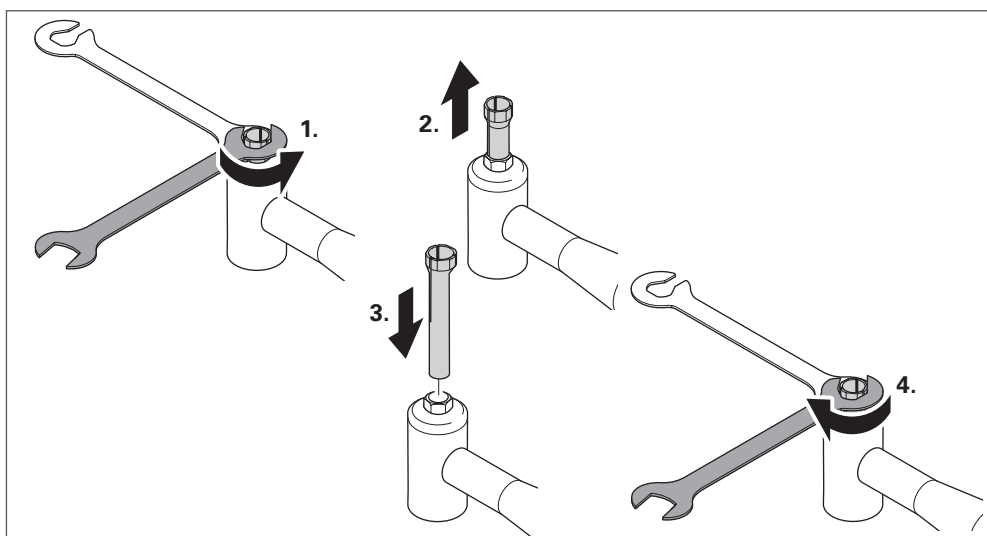

Fig. 45

15.2.9 JERA 270 S

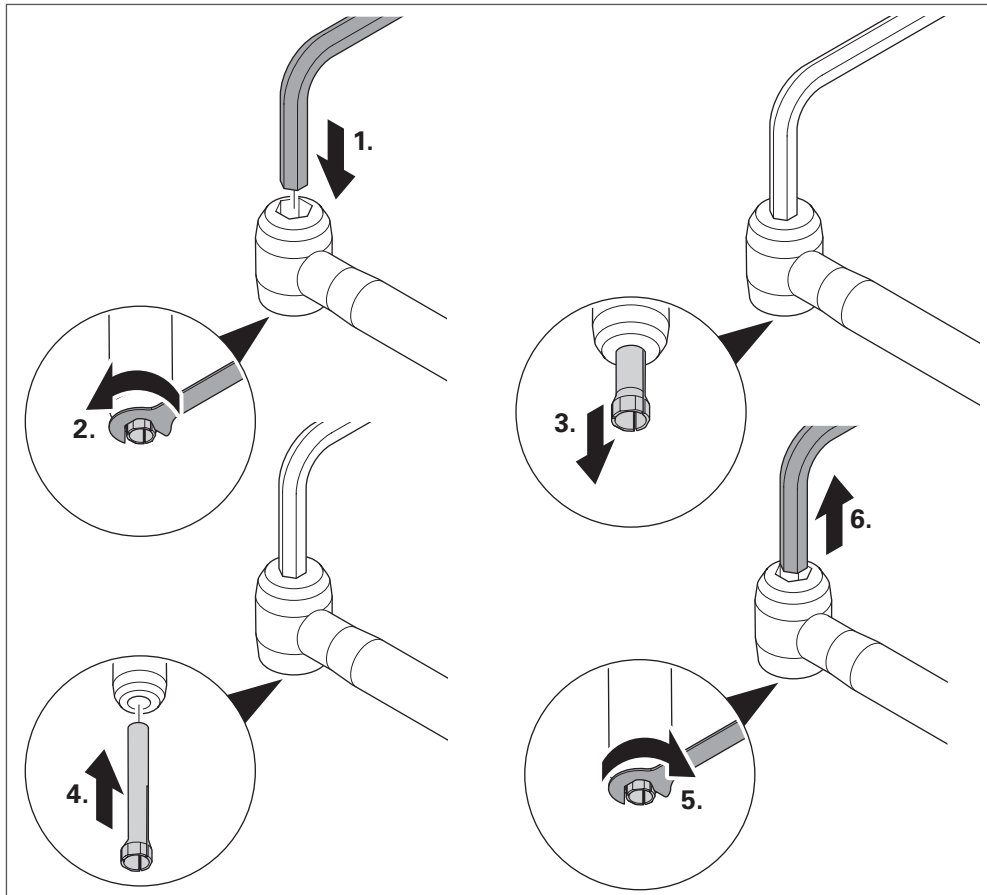

Fig. 46

15.2.10 JIH 300, JIH 40R

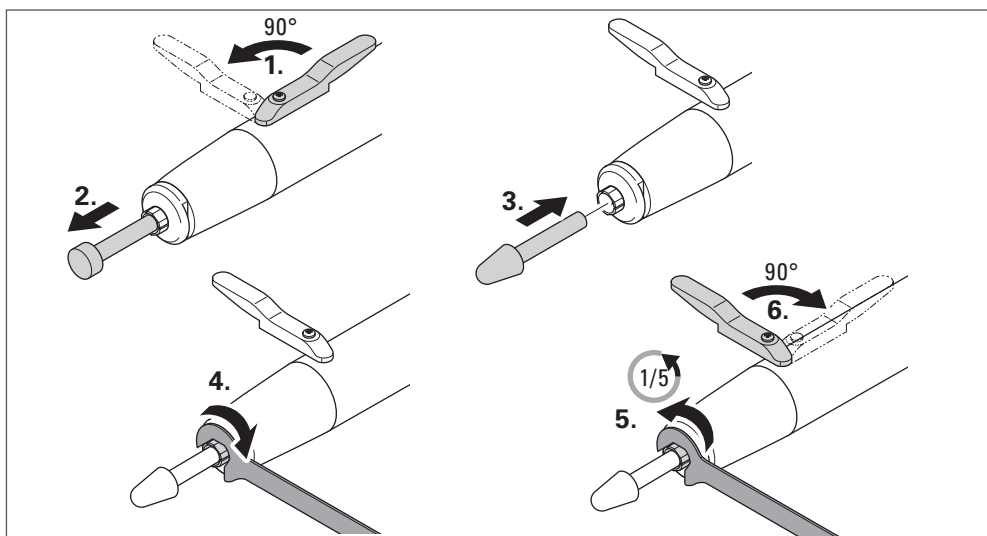

Fig. 47

**15.2.11 JKC 345, JIC 390, JEKC 300, WE4-45, WE4-90, JERA 90 20R, JEAH 60 20R**

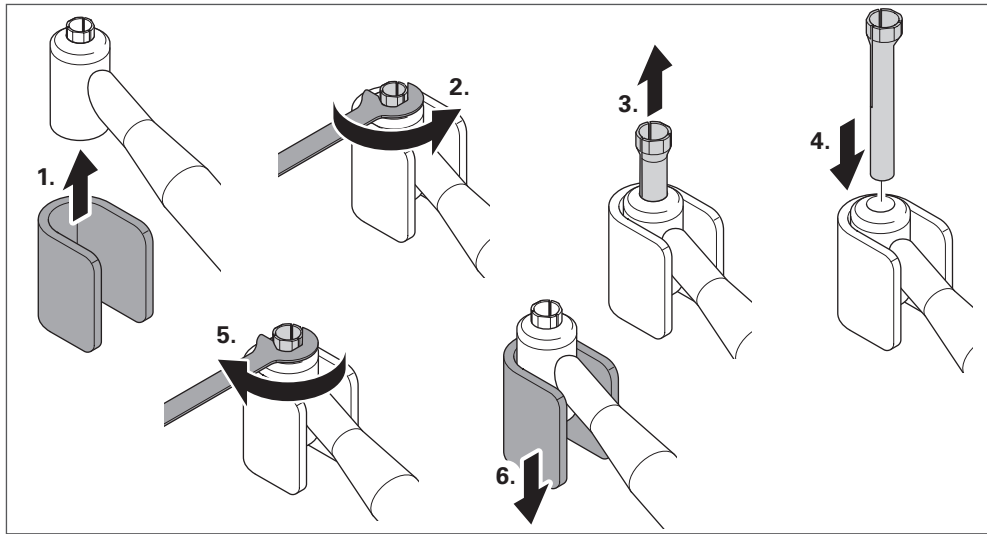

Fig. 48

**15.2.12 JMFC 300 S, JMFC 300 M**

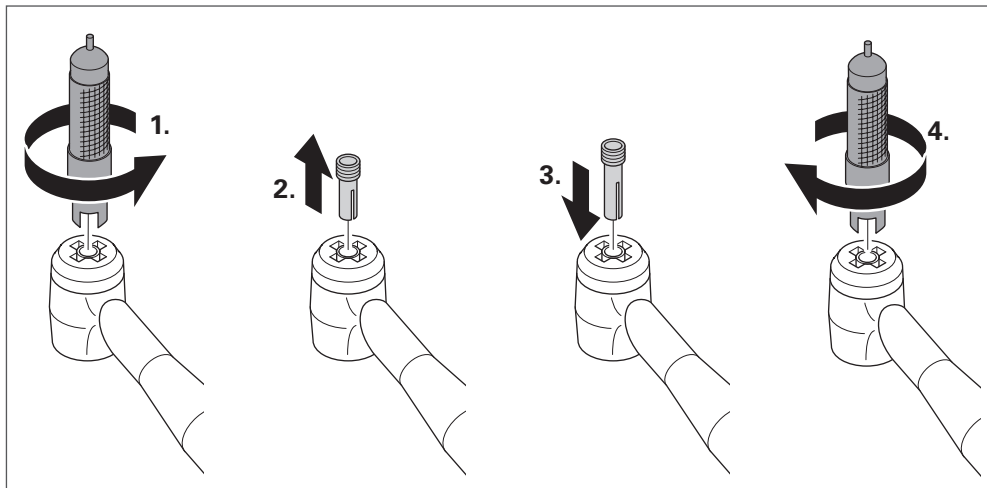

Fig. 49

## 16 Maintenance, care and disposal



### Attention!

- ▶ Clean all components with a dry, soft, lint-free cloth only.
- ▶ Do not use chemical cleaning agents such as alcohol, acetone, nitro-dilution.

The control unit should be serviced once a year by joke Service.

Handpieces and brushless joke motors are maintenance-free.

- ▶ Check the mains cable regularly for damage and replace it if necessary.
- ▶ Service, maintain and dispose of carbon brush motors as described in the corresponding manufacturer's instructions.
- ▶ Clean and oil the collets at least once a week (changing the collets see chapter 15.2 on page 45).
- ▶ Dispose of all components properly. Do not dispose of them with household waste.

### 16.1 Servicing and maintenance instructions

After approx. 4 200 operating hours, the message "S E R V I C E" appears in the display after each unit start. The "S E R V I C E" message is repeated until it is reset by joke Service.

- ▶ Contact joke Service and make an appointment if necessary.

If you have any questions about spare parts and repairs, please contact joke Service.

## 17 Troubleshooting

The control unit is equipped with an overload switch. If the handpiece or the micromotor is continuously subjected to maximum load, overload protection is triggered. The motor controller then switches the motor off and the motor cannot be switched on initially. In this case, wait approx. 3 – 5 seconds and then continue working with a reduced load.

Fault/ error code	Cause	Remedy
The display is not lit.	• The control unit is not switched on.	▶ Switch on the control unit.
	• The mains cable is not connected.	▶ Connect the mains cable.
	• The micro-fuse in the control unit is faulty.	▶ Replace the defective micro-fuse.
	• Control unit, cables, connections, contacts, mains switch or sockets are faulty.	▶ Send the unit and accessories to joke Service for inspection or repair.
The motor will not start. The tool does not rotate.	• The motor or handpiece have been overloaded.	▶ Do not load the unit and accessories any longer, wait 3 – 5 seconds and, following that, do not load the unit and accessories to their maximum.
	• The quick-release lever on the handpiece is open.	▶ Fit the tool correctly.
	• The quick-release lever on the handpiece is not closed.	▶ Close the quick-release lever or the quick-release head.
	• The locking pin is still inserted.	▶ Remove the locking pin.
	• The collet or tool is jammed.	▶ Adjust the collet. ▶ Fit the tool correctly.
	• Electrical contacts are faulty.	▶ Check the motor connections. ▶ Check the connections between the motor and the accessory.
	• The carbon brushes are worn out.	▶ Replace the carbon brushes.
• Motor, circuit, cable, connections, contacts or sockets are faulty.	▶ Send the unit and accessories to joke Service for inspection or repair.	
E1/E3/E6	Overcurrent fault	▶ Restart the motor.
E2	Commutation error, shaft blocked at start.	▶ Restart the motor. ▶ In the event of a motor fault or cable breakage: Send the unit and accessories to joke Service for inspection or repair.
E4	Overcurrent limitation, motor draws too much current.	▶ Replace the motor. ▶ Send the unit and accessories to joke Service for inspection or repair.
E5	Switching 115/230 V~, DC link error	▶ Check the mains power input. ▶ Send the unit and accessories to joke Service for inspection or repair.
E7	Excess current warning	Self-deleting

Fault/ error code	Cause	Remedy
E8	Unit error	<ul style="list-style-type: none"> <li>▶ Switch the unit off and then on again.</li> <li>▶ Replace the motor.</li> <li>▶ Send the unit and accessories to joke Service for inspection or repair.</li> </ul>
E9	Main board overtemperature: <ul style="list-style-type: none"> <li>• If the temperature is &gt; 80 °C, the unit switches off automatically</li> <li>• If the temperature is &lt; 70 °C, the unit is automatically switched on again</li> </ul>	<ul style="list-style-type: none"> <li>▶ Let the unit cool down when it is switched off.</li> </ul>
E10	The DC link voltage when switched on exceeds 5 V.	<ul style="list-style-type: none"> <li>▶ Send the unit and accessories to joke Service for inspection or repair.</li> </ul>
E13	Overtemperature of the DC auxiliary board: <ul style="list-style-type: none"> <li>• If the temperature is &gt; 75 °C, the unit switches off automatically</li> <li>• If the temperature is &lt; 50 °C, the unit is automatically switched on again</li> </ul>	<ul style="list-style-type: none"> <li>▶ Let the unit cool down when it is switched off.</li> </ul>
PLC motor code	Start command of the PLC does not detect a connected motor or the running motor loses the motor signal.	<ul style="list-style-type: none"> <li>▶ Re-insert the motor cable.</li> <li>▶ Replace the motor cable.</li> </ul>



## Declaration of Conformity

We, joke Technology GmbH  
Asselborner Weg 14–16  
51429 Bergisch Gladbach, Germany  
Germany

declare under our sole responsibility that the product

**Designation: Grinding, milling, deburring and polishing system**

**Type designation: ENESKAmicro**

complies with the provisions of the following directives and standards:

- **Machinery Directive 2006/42/EC**
- **Electromagnetic Compatibility Directive 2014/30/EU**
- **Directive 2014/35/EU (Low Voltage Directive).**
- **DIN EN ISO 12100 (2011-03): Safety of machinery – General principles for design – Risk assessment and risk reduction**
- **DIN EN 62841 (2016-07): Electric, motor-driven hand-held tools, transportable tools and lawn and garden machines – Safety – Part 1: General requirements**
- **DIN EN 61010-1 VDE 0411-1 (2011-07): Safety requirements for electrical equipment for measurement, control and laboratory use – Part 1: General requirements**

The authorised representative for the document is:

Kerstin Otto

joke Technology GmbH, Asselborner Weg 14-16, 51429 Bergisch Gladbach, Germany

Bergisch Gladbach, 31 January 2023

Udo Fielenbach (Managing Director)





## Declaration of Conformity

We, joke Technology GmbH  
Asselborner Weg 14–16  
51429 Bergisch Gladbach, Germany  
Germany

declare under our sole responsibility that the product

**Designation: Motors and handpieces of the 3rd generation**

**Type designation:**

**Motors:**

**ENESKAmicro COMPACT REM 50C, COMPACT REM 50C CNC, JEM 50R, JEM 40R, JEM 20R,**

**Handpieces:**

**JIR 40R, JBMXLH 40R, JEHG 20R, JMH 20R, JERA 90 20R, JEAH 60 20R, JBS 20R**

complies with the provisions of the following directives and standards:

- **Electromagnetic Compatibility (EMC) Directive:200 4 /108/EC**  
using the following harmonised standards:  
**EN610006 4:2007, +A1:2011**  
**(EN610006 2:2005(EMS)**
- **Directive: Low Voltage Directive (LVD): 2006/95/EC**  
using the following harmonised standards  
**IEC607451 4:2006**  
**IEC607452 3:2006+A1:2 010+A2:2012 2.**
- **Directive:RoHS Directive :2011/65/EU**  
using the following harmonised standards  
**EN50581:2012**

The authorised representative for the document is:

Kerstin Otto

joke Technology GmbH, Asselborner Weg 14-16, 51429 Bergisch Gladbach, Germany

Bergisch Gladbach, 31 January 2023

Udo Fielenbach (Managing Director)





***Brilliant solutions for perfect surfaces***

joke Technology GmbH  
Asselborner Weg 14 – 16  
51429 Bergisch Gladbach, Germany  
Germany  
**Tel.** +49 22 04 8 39-0  
**Mail** [info@joke.de](mailto:info@joke.de)  
**Web** [www.joke-technology.com](http://www.joke-technology.com)

**Order number for operating manual: BA2241GB**